



North American Terrazzo, Inc.

501 South Lucile, Suite 100, PO Box 80544, Seattle, WA 98108
Office (206) 762-2803 Fax (206) 762-2409

To simplify the specification of Terrazzo, the Technical Committee of The National Terrazzo & Mosaic Association has prepared this book containing the latest specifications, details and technical data as a single source of information. Specifications are complete and may be copied directly, thereby ensuring quality installations.

TABLE OF CONTENTS

INTRODUCTION	2
Marble Chips	2
Matrices	2
Divider Strips	2
Control Joints	4
GENERAL INFORMATION	3
Divider Strip Usage	3
Allowance for Finish	4
Fire Endurance of Terrazzo Floors	4
Care of Terrazzo	5
Glossary	5
Terrazzo Floor Finished Surface Flatness Tolerance	6
GUIDE SPECIFICATIONS	7
Cementitious Terrazzo:	
Sand Cushion Terrazzo	7
Bonded Terrazzo	10
Monolithic Terrazzo	13
Structural Terrazzo	16
Rustic Terrazzo:	
Structural System over Granular Fill	19
Bonded System with Setting Bed, Over Concrete Slab	22
Direct Bond to Concrete Slab	24
Unbonded Rustic Terrazzo	27
Palladiana	30
Terrazzo Over Permanent Metal Forms	33
Terrazzo Base: Precast	36
Terrazzo Base: Poured in Place	38
Terrazzo Stairs: Precast	40
Restoration of Terrazzo Finish	41
Terrazzo Stairs: Poured in Place	42
Vertical Terrazzo	45
Modified Cementitious Terrazzo:	
Polyacrylate Modified Terrazzo	48
Resinous Terrazzo:	
Epoxy Terrazzo	51
Conductive Terrazzo	53
Polyester Terrazzo	54
Epoxy Terrazzo Accent Features in Sand Cushion Terrazzo	57
Fine Aggregate Floors:	
Trowel-Finished Epoxy Floors	60
Fine Aggregate Epoxy Floors	63
Thin Set Terrazzo Finishes, Preparation of Concrete Slab-On-Grade Substrates	66
Recommendations for Monolithic Terrazzo	69

Copyright 1999 by The National Terrazzo & Mosaic Association, Inc.

INTRODUCTION

TERRAZZO: Derived from the Italian “Terrace” or “Terrazza” and by definition over the centuries: “A form of mosaic flooring made by embedding small pieces of marble in mortar and polishing.”

Today, the National Terrazzo and Mosaic Association (NTMA) defines this traditional material as follows: “Terrazzo consists of marble, granite, onyx or glass chips in portland cement, modified portland cement or resinous matrix. The terrazzo is poured, cured, ground and polished. Typically used as a finish for floors, stairs or walls, Terrazzo can be poured in place or precast.”

“Rustic Terrazzo is a variation where, in lieu of grinding and polishing, the surface is washed with water or otherwise treated to expose the chips. Quartz, quartzite and river bed aggregates can also be used.”

“Mosaic is an artistic finish composed of small hand cut pieces of smalti, glass or marble called tessarae. The tessarae are mounted on paper by hand to form mosaic sheets. These sheets of mosaic are then set in mortar on the job site to create beautiful patterns, designs, and murals.”

MARBLE CHIPS: Marble has been defined as a metamorphic rock formed by the recrystallization of limestone. However, in recent decades, marble has been redefined to include all calcareous rocks capable of taking a polish (such as onyx, travertine, and attractive serpentine rocks). Marble is quarried, selected to avoid off color or contaminated material, crushed and sized to yield marble chips for Terrazzo. Excellent domestic and imported marble chips are available for use in terrazzo in a wide range of colors and can be combined in infinite varieties to create color harmonies of every description.

MARBLE CHIPS SIZES: Marble chips are graded by number according to size in accordance with standards adopted by producers as follows:

Number	Passes Screen (in inches)	Retained on Screen (in inches)
0.....	1/8	1/16
1.....	1/4	1/8
2.....	3/8	1/4
3.....	1/2	3/8
4.....	5/8	1/2
5.....	3/4	5/8
6.....	7/8	3/4
7.....	1	7/8
8.....	1 1/8	1

CUSTOMARY SIZES FOR TOPPINGS:

1. Standard: No. 1 and 2.
2. Intermediate: No. 1, 2, 3, and 4.
3. Venetian: No. 1, 2, 3, 4, and 5; and/or 6, 7, and 8.
4. Resinous: (1/4 inch thickness) No. 1 and 0.
5. Resinous: (3/8 inch thickness) No. 1, 2, and 0.

NOTE: Marble chip quarries normally produce 0, 1, and 2 as separate sizes, Larger sizes are frequently grouped; for example #3-4 mixed and #7-8 mixed, and #4-7 mixed. #00 chips (1/16 to 1/32 inch size) are available for use in industrial floors.

SELECTING MARBLE CHIPS: It is highly desirable that color combinations be designated by NTMA plate numbers (NTMA Color Plates). In the absence of NTMA color plates, it is important that the size and color combinations be shown due to price differentials.

MATRICES: The matrix is the ingredient in a terrazzo floor which acts as a binder to hold the chips in position. There are three basic types of matrices: cementitious, modified-cementitious and resinous.

CEMENTITIOUS MATRICES: Portland Cement provides a good background for marble chips. It can be tinted to produce various colors. White cement is color controlled during manufacture. Gray Portland Cement may not be color controlled. For use in terrazzo, portland cement should exceed the minimum standards of ASTM C-150.

MINERAL COLOR PIGMENTS: Interior: Shall not exceed two pound per bag of portland cement. Exterior: Pigment shall not exceed 1/2 pound per bag of Portland Cement.

MODIFIED CEMENTITIOUS MATRICES: Polyacrylate Modified Cement: A composition resinous material which has proven to be an excellent binder for use in thin-set terrazzo. Minimum physical properties are stipulated in Polyacrylate Terrazzo specification.

RESINOUS MATRICES: EPOXY OR POLYESTER: A two component thermal setting resinous material which has proven to be an excellent binder for use in thin-set terrazzo. Minimum physical properties are stipulated in NTMA Terrazzo specifications.

DIVIDER STRIPS: White alloy of zinc, brass or plastic are used for function and aesthetics. Brass and plastic may have a reaction with some resinous materials and should be used only if deemed safe by the supplier of the resin.

The following are the most common types of strips available (in some systems, the strips act as control joints).

1-1/4 inch Standard Divider Strip with anchoring device. Available in white alloy of zinc or brass and 14, 16 or 18 B & S gauge. Extensively used in Sand Cushion, Bonded to Concrete, Structural and other types of cementitious terrazzo systems. Also used in monolithic terrazzo where slab has been recessed or sawn to create a weakened vertical plane. Available in 1-1/2 inch and greater depths for Venetian Terrazzo control joints and special conditions.

1-1/4 inch Heavy Top Divider Strips with anchoring device. Available in white alloy of zinc or galvanized steel bottom section. Top section available in white alloy of zinc, brass or colored plastic. Width of the top section is 1/8, 1/4, 3/8, or 1/2 inch. Basic use is the same for the 1-1/4 inch Standard Divider Strip. (Some plastic strips are 3/16 inch and 5/16 inch instead of 1/8, 1/4 and 1/2 inch).

Terrazzo Specifications & Design Guide

K or L Strips in standard gauges or with the heavy top feature for use in monolithic or resinous "thin-set" systems. Sizes vary according to the depth of the terrazzo topping. Can be attached to substrate with adhesive compatible with topping matrix.

Basic Terrazzo Systems Information Available to Fit Variable Job Conditions

System	Description	Advantages	Thickness	Weight	Dividers
Epoxy \$\$\$	A nominal 1/4" or 1/8" thick resin matrix veneer placed upon a level concrete slab; Also can be specified with glass, synthetic, or granite aggregates in lieu of marble to provide brilliant colors or chemical resistance; The best "thin-set" system.	Unlimited matrix colors, color control, resiliency, chemical resistance and tensile-compressive strengths not found in cement based systems. Excellent for multi-colored patterns and designs. Light weight and flexibility make it ideal for multi-story use. It has the lowest maintenance cost due to non-absorbancy*. In sanitary areas can be installed with minimal dividers providing seamless characteristics. When used in conjunction with a flexible membrane as a specified extra, it can absorb some horizontal concrete crack or control joint movement. It also has the quickest pour to grind installation time. Can also be used over properly installed and prepared plywood. Glass and other decorative aggregates increase cost.	Nominal 1/4" or 1/8" Epoxy Terrazzo topping. 0-1 chip sizes opt. #2 chip for 1/4"	3-4 lbs. PSF.	All these systems adhere to the concrete and require dividers to be placed precisely above any concrete joints. To prevent the concrete from cracking and therefore the terrazzo, "ACI 302.1 R.89 Concrete Joint Placement" must be followed. Some of these requirements include: Concrete joints should occur a maximum of three times in feet the depth of the concrete in inches. (Example: A 4 inch slab should have concrete joints at a maximum spacing of 12 feet.) Concrete joints should run off all corridor intersections and corners. They should not be spaced more than 1 1/2 times the width of the concrete pour. (Example: A 6 foot wide corridor should have concrete joints at a maximum of 9 feet.)
Polyacrylate \$\$	A nominal 1/2-inch thick polymer modified cement matrix veneer placed upon a provided level concrete slab. Polymer provides strength to allow for thinner applications of cementitious systems.	Fast installation and moderate price range make it ideal to replace vinyl or carpet without depth transition difficulties; also good to use in areas subject to moisture vapor transmission where Epoxy terrazzo or other non-breathing floors will not adhere.	Nominal 1/4" Polyacrylate with Terrazzo topping. Chip sizes 0, 1 & 2.	4 1/2 lbs. PSF.	In addition other dividers can be set to separate colors or as an accent themselves. In these systems the dividers not located over concrete joints are strictly decorative. They do not function as leveling devices or crack preventers.
Monolithic \$	This 1/2-inch thick cement matrix veneer placed upon a provided concrete slab is dependent on the concrete quality for flatness and crack prevention. On grade or below grade only.	Fast installation and the most economical price make it ideal where time and budget are critical but where the beauty, low maintenance and the performance of terrazzo is desired.	1/2" Terrazzo topping.	5-7 lbs. PSF.	Dividers vary in width from 18 gauge to 1/2 inch. 16 gauge or 1/8 inch are standards. Zinc is standard but brass and colored plastic are readily available. Architects should design structural inset expansion plates between areas where major movement is anticipated.
Bonded \$\$\$	A cement matrix and underbed system for interior and exterior areas where conditions require 1 1/4 inches to 1 3/4 inches of recessed depth to be filled in addition to the 1/2 inch terrazzo topping.	With the sand-cement underbed it has less dependence on the concrete slab for flatness when compared to monolithic.	1 1/4" to 2 1/4" including 1/2" Terrazzo topping.	18-22 lbs. PSF.	
Sand Cushion \$\$\$	A cement matrix topping underbed with wire reinforcing, isolation sheet, and sand layer system for interior floor use. This is the best cement based system.	Due to the underbed's depth, wire mesh reinforcing, isolation sheeting and sand layer it will absorb minor substrate defects and prevent mirroring to the surface.	2 1/2" to 3" including a 1/2" Terrazzo topping.	25-30 lbs. PSF.	The position of divider strips is essential to performance, serving a dual function: a control for anticipated contraction and an aesthetic enhancement in separating colors. 5 feet or less on centers. Architects should design structural inset expansion plates between areas where major movement is anticipated.
Structural \$\$\$	For large areas over a graded compacted base. Involves 4" of 3,500 PSI underbed concrete plus 1/2" Terrazzo topping.	Single contract control: One contractor places both the concrete slab and the finished terrazzo surface.	4 1/2" to 6", including a 1/2" Terrazzo topping.	Approx. 60 lbs. PSF.	Divider strips are deeper than usual: 1 1/2 inch to 2 inches inserted into the underbed 8 feet to 10 feet on centers. Control strips are provided on column lines.
Rustic \$ varies with system	Terrazzo with a non-ground, textured surface, for exterior use. This system is available with Sand Cushion, Bonded, Structural and Monolithic or any cement system.	Infinitely variable textures, colors and patterns may be created in a weather-resistant, skid-resistant deck surface.	1/2" to 6" including a 1/2" Terrazzo topping.	Dependent on system selected	Temporary wood strips are used, then replaced by a pourable sealant inserted into the joint.
Precast	Prefabricated custom units for steps, bases, planters, benches, wall panels, etc.	Unlimited uses.		Custom finished	

§ These are relative symbols. There is a wide array of pricing within systems and geographic regions. For instance it is possible to design a Monolithic Terrazzo system as costly as an inexpensively designed Sand-Cushion system. Price factors include: pattern complexity; number of different colors; local labor rates; divider strip quantity and type; size and source of aggregate; size of areas and total project; number of phases and logistics; new constructions or renovations. Consult your local NTMA contractor for budget pricing. Some national pricing data such as Means is as much as 100% off.

* Non-Absorbancy is an asset in epoxy terrazzo that also causes a word of caution. Epoxy Terrazzo like any other non-breathing floor such as rubber sheet flooring is susceptible to debonding by moisture vapor transmission on slabs on grade. Consult Epoxy Manufacturer for proper concrete and waterproof membrane measures to prevent this occurrence.

General Note: The standard finish on terrazzo is an 80 grit carborundum polish. When used in conjunction with a U/L listed "slip resistant" sealer this provides a 0.6 anti-slip coefficient of friction. Higher polish grits that tend to deepen and darken the aggregates are available.

Terrazzo Specifications & Design Guide

CONTROL JOINTS: Double "L" strips (Angle strips) or straight strips positioned back to back are effective in allowing for anticipated shrinkage in the subfloor at construction joints. Double "L" (Angle strips) are used for Thin-set and Monolithic systems.

In Sand Cushion Terrazzo, the employment of the normal single divider strips, regardless of the gauge inserted in the Sand Cushion underbed up to five foot or less on centers, provides ample control of anticipated shrinkage that will take place when the terrazzo work is installed in accordance to these specifications as each divider picks up a minute amount of the contraction.

Construction joints in the structural slab have no bearing on the placement of divider strips in a Sand Cushion system due to the use of an isolation membrane.

NOTE: It is not this Association's intent to make expansion joint recommendations. Architects should specify expansion joints and indicate locations and details on the project drawings.

STANDARD TERRAZZO: By customary reference, the standard terrazzo toppings have been understood to mean No. 1 and No. 2 size marble chips.

THIN-SET TERRAZZO: Chips used in thin-set terrazzo (modified cementitious and resinous terrazzo) may, if the cross-section is less than 3/8 inch, require the use of No. 1 and No. 0 chips only. Three eighths inch thickness is required if #2 size chips are desired.

MINERAL PIGMENT: When it is necessary for aesthetics reasons to use an artificially colored matrix, utmost care should be exercised in obtaining a lime proof mineral or synthetic pigment compatible with portland cement.

INTERIOR: Never use more than 2 pounds of pigment per bag of portland cement. Use 1/2 pound for exterior installations.

VENETIAN TERRAZZO: (Cement binders only) Toppings incorporating marble chips larger than the intermediate sizes are usually referred to as Venetian toppings. The minimum topping thickness for Venetian Terrazzo is 5/8 inch.

TERRAZZO FINISHES: Terrazzo systems must be given an application of penetrating type sealer to fill the pores of the surface to prevent, in large measure, absorption of traffic dirt and stains, as well as to facilitate their removal in routine care with neutral cleaners. Sealers will also highlight the natural color of aggregate.

ALLOWANCE FOR FINISH

Type Installation	Allowance for Finish (nominal thickness)	Weight (per sq. ft)
Sand Cushion	2-1/2"	30 lbs.
Bonded	1-3/4"	20 lbs.
Monolithic	1/2"	6 lbs.
Venetian	2-3/4"	36 lbs.
Epoxy	1/4"	3 lbs.
Polyester	1/4"	3 lbs.
Polyacrylate Modified	1/4"	3 lbs.
Palladiana	3"	36 lbs.

NOTE: THE ABOVE MINIMUM THICKNESS ALLOWANCES FOR FINISH MAY BE INCREASED, WITH CORRESPONDING INCREASE IN DEAD LOAD COMPUTATIONS. THE ABOVE STANDARD ALLOWANCES FOR FINISH ARE THE MINIMUM APPLICABLE FOR THE TYPE FINISH INDICATES AND GOVERN ALL DETAILS HEREIN.

FIRE ENDURANCE OF TERRAZZO FLOORS

Extract from "FIRE ENDURANCE OF TWO-COURSE FLOORS AND ROOFS", by M.S. Abrams and A.H. Gustafarro, Portland Cement Association, published in the February 1969 issue of the Journal of the American Concrete Institute.

TERRAZZO: One specimen was of monolithic terrazzo, i.e., the terrazzo was placed on the base slab a few hours after the base slab was cast but before the base slab had hardened. No ties were used between the two courses. Two specimens were of sand cushion terrazzo, i.e., the underbed was isolated from the base slab by a layer of sand 1/4 inch (6mm) thick, and a layer of building paper. The sand cushion terrazzo specimens were cast within sheet metal side frames and were kept in a horizontal position to prevent disturbance of the sand layer. Except for the monolithic terrazzo, the base slabs were cured 5 days under damp burlap before the underbed and terrazzo were applied. The underbed consisted of one part cement and about 4-1/2 parts sand (by dry loose volume) with just enough water to permit molding. The underbed was tamped into place and several different types of divider strips (brass, white metal, and plastic) were used. Various colors of 1/4 to 3/8 inch (6 to 10 mm) marble chips were used in the terrazzo. One day after placement, the terrazzo was ground, but not polished. All terrazzo work was done by qualified terrazzo mechanics.

Two additional specimens were cast entirely of the underbed mixture.

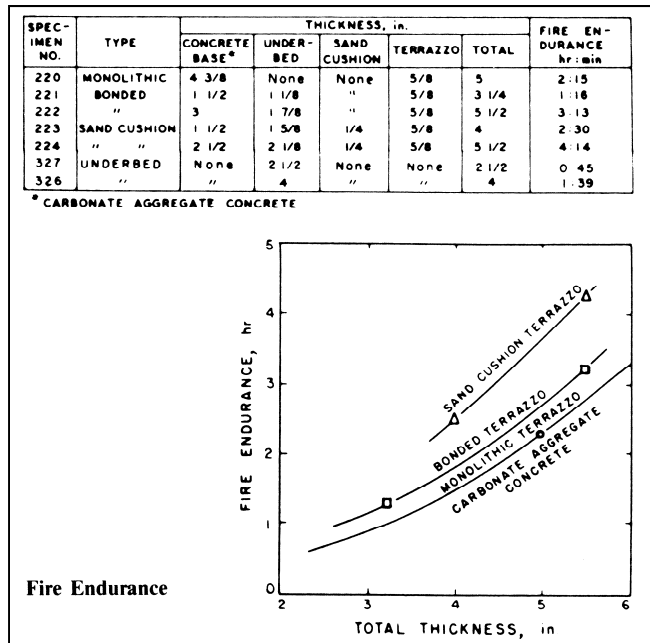

Terrazzo floor data is shown in the chart below. In each of the tests of terrazzo floors, the average temperature rise of the unexposed surface of 250 degrees F (139C) governed, even though two thermo-couples were located over divider strips. The fire endurance of the 5 inch (12.7 cm) monolithic terrazzo specimen was about the same as that of a 5 inch (12.7 cm) single-course slab. Two specimens of bonded terrazzo had endurance periods 16 and 24 minutes longer than single course specimens of the same total thickness. The sand cushion terrazzo specimens had endurance periods more than 1 hour longer than single course slabs of the same total thickness.

In an attempt to determine the reason for the longer fire endurance of the terrazzo floors, two slabs of terrazzo underbed were cast and fire tested. Specimen 327 was 2-1/2 inches (6.35 cm) thick and had a fire endurance of 45 minutes. Specimen 326 was 4 inches (10.2 cm) thick and had an endurance of 1 hour 45 minutes. These endurance periods were about 10 percent longer than for similar thicknesses of carbonate aggregate concrete and about 25 percent longer than for siliceous aggregate concrete.

CARE OF TERRAZZO

It is doubtful that there is a flooring material in use today that is as care-free as terrazzo. Yet, a number of people have difficulty in maintaining it. Like other materials, there are inherent properties of terrazzo that should be understood. Once understood, maintenance problems are eliminated and the full beauty as well as economy is realized. To best understand terrazzo, you must first break it down into components. Terrazzo consists of marble chips and/or other aggregates in combination with a binder of portland cement or a resinous material such as epoxy, polyester, or polyacrylate. The marble chips and/or aggregates are mixed with the binder at a ratio of 2 to 1 (Chips to Binder.) During the installation of terrazzo, additional chips may be sprinkled on the surface so that a minimum density of 70% marble chips appears on the finished surface.

PROTECTION: When dealing with terrazzo, the use of a pure surface coating (as most floor waxes are) is unnecessary and ordinarily NOT recommended. The terrazzo surface is at least 70% marble or aggregate. Applying a surface coating or wax may decrease the non-slip co-efficient of friction below the standard rating of 0.5. The marble chips and aggregates (which make up 70% of the terrazzo floor) have very low porosity and do not absorb most staining substances. The portion of the terrazzo that needs protection is the binder, especially portland cement, which is porous and will absorb stains. Terrazzo does not need protection from wear, it needs protection from absorption and this is achieved though the use of penetrating sealer which seals off the pores in the binder.

INTERNAL PROTECTION: Proper protection for terrazzo is accomplished internally rather than "on the surface." Being internal, the process of waxing and rewaxing is eliminated. Only periodic resealing are necessary using a sealer that has a non-slip rating of 0.5 or higher. It is wise to note here that purely surface protection holds dirt and adds to your cleaning and/or presents a stripping problem. There are few natural products as beautiful as marble. Shoe leather is one of the finest polishers of terrazzo and daily use allows it to develop a beautiful, natural sheen or patina.

NEUTRAL CLEANERS

Cleaning : Terrazzo should be cleaned only with neutral liquid cleaners. The cleaning cycle to be set up should be regulated by the amount of traffic. After mopping your cleaning solution onto the floor, allow several minutes for the grime-dissolving action to take place, then squeegee, wet vacuum, or mop up the dirt laden solution. It is important to keep the floor wet during the entire cleaning process so the dirt does not reabsorb into the floor. Also, it is ABSOLUTELY NECESSARY THAT YOUR RINSE WATER, MOP AND PAIL ARE CLEAN so that dirt is not reapplied to the floor.

Cleaning Materials: The liquid cleaner selected MUST be neutral with a pH factor between 7.0 and 10.0. The cleaner must also be free from any harmful alkali, acid, etc. that might damage the floor. The NTMA specifically warns that soaps containing water solubles, inorganic salts or crystallizing salts should NEVER be used in the maintenance of terrazzo; some terrazzo floors have been damaged by improper selection of cleaning materials.

NON-OILY DRESSINGS

If a mop dressing is used for daily sweeping, be sure it is non-oily. Sweeping compounds containing oil are a fire hazard and most of them contain sand, which is hard to sweep up and abrades the floor. Floor oils also penetrate and permanently discolor terrazzo.

CURING AND AESTHETICS

New terrazzo floors require time and patience to allow the curing process to run its natural course. It is also a fact that many terrazzo colors will appear mottled initially. This does not indicate that the installing contractor did not execute properly. This less than desirable appearance is often beyond the control of the terrazzo contractor as it is the normal characteristics of the system. It is a fact that, initially, the aesthetics of a new terrazzo floor is far from what is desired, but it is predictable that with each passing day the aesthetics will increase and the results of a good installation will be recognized. This provides the owner with the performance, aesthetics and ease of maintenance for the life-long expectancy known by the history of terrazzo.

GLOSSARY

The following definitions are intended to clarify the terms used in this book.

AGGREGATE: A granule, other than marble, used in the topping, i.e., abrasive, quartz, river gravel, synthetic types, etc. For our purpose, marble will be referred to as "chips."

ART MARBLE: Artificial marble; precast terrazzo.

BONDING AGENTS: Materials generally applied to "thin-set" terrazzo: i.e., latex, epoxy, or other types of adhesives. Used to increase adherence of the terrazzo mix to an existing base slab, also known as primers.

BROKEN MARBLE: Fractured slabs of marble (not crushed by machines into chips.)

CHIPS: Marble granules screened to various sizes.

CLEANER: A neutral liquid cleaner used to remove accumulated surface dirt.

COLOR PIGMENTS: Inorganic matter used in the terrazzo mix to vary the color. A powdered substance which, when blended with a liquid vehicle, gives the matrix its coloring.

CONTROL JOINTS: Allowance made by use of a strip, saw cut or other device to allow for movement without damaging the terrazzo.

CURING: The maintaining of proper moisture and temperature conditions necessary for the normal hydration of portland cement to take place.

GROUT: A mixture of the paste used as the binder and sometimes color pigment applied to the floor to fill the voids and pits after rough grinding.

MARBLE: A metamorphic (recrystallized) limestone, composed predominantly of crystalline grains of calcite or dolomite or both, having interlocking or mosaic texture.

MATRIX: The portland cement and water mix or non-cementitious binder used to hold the marble chips in place for the terrazzo topping.

MONOLITHIC: Cementitious terrazzo topping applied to structural slab provided by others.

PANELS: The spaces formed by the divider strips.

PLATE NUMBERS: Numbers appearing adjacent to the various terrazzo illustrations in the NTMA Terrazzo Information Guide. Often used in lieu of formulae in job specifications.

PRECAST: Fabricated in molds, and finished in a shop or factory, by a compression and vibratory method.

SCREED: To level the top of a mortar bed with a wood or metal straight edge.

SEALER: A required protective coating or treatment which precludes foreign liquid or matter from being absorbed, by closing the pores in the surface.

SURFACING: The grinding, grouting and polishing operations on terrazzo topping.

SWIRL MARKS: When using fine polishing stones in the final stage of finishing the terrazzo, it is normal to expect swirl marks. These markings will disappear rapidly with normal maintenance procedures and foot traffic.

SLIP-RESISTANT PROPERTIES: It is normal that the final polishing of Terrazzo be completed with fine polishing stones to meet the requirements of a safe walking surface. Sealers should be U/L listed as "Slip Resistant."

TESSERAE: Thin slices of marble, colorful stone, or glass like highly colored vitreous enamel material cut into squares or other shapes of any size. Used in mosaic work.

THINSETS: Terrazzo systems which can be applied in a thin cross section (3/8 inch or less) over concrete or other suitable substrates.

TOPPING: The wearing surface of the terrazzo floor.

UNDERBED: Cementitious materials to support divider strips and terrazzo topping.

TERRAZZO FLOOR FINISHED SURFACE FLATNESS TOLERANCE

FLATNESS TOLERANCE: The finished terrazzo floor shall not vary more than plus or minus 1/4 inch in a ten foot span.

Often times, a perfectly acceptable terrazzo floor in a large area with one or more window walls will appear to have variations greater than the above tolerance. The optical illusion is further magnified if the floor has a high polish.

It is important to realize that Monolithic and Thin-set Terrazzo toppings are a veneer and will automatically follow the contour of the concrete subfloor. Therefore, it is mandatory that the concrete subfloor have the same tolerance of plus or minus 1/4 inch in a ten foot span. When corrections to nonconforming concrete subfloors are necessary, they are the responsibility of the concrete contractor but the materials used shall be approved by the Terrazzo contractor.

MONOLITHIC AND THIN-SET TERRAZZO: Divider strip spacing is dictated by the concrete joint locations. It is essential that the structural engineer design concrete control joints to prevent random cracking. General guidelines for concrete joints in accordance with ACI 302.1 R.89. Rectangle shaped concrete panels should not be longer than 1-1/2 times the width. Two angle type divider strips placed back to back over such joints is a requirement, with the same width through the Terrazzo topping that appears in the substrate. It may be necessary to place a temporary wood strip between the divider strips, remove the wood once the Terrazzo floor has been finished and caulk the void with a flexible sealant.

All divider strips used in a monolithic or thin set Terrazzo floor system have no function other than aesthetics, unless placed over a break in the substrate. It is normal to use divider strips for design or color changes.

GUIDE SPECIFICATION FOR SAND CUSHION TERRAZZO

(Revised 6/94 Supersedes all previous specifications for Sand Cushion Terrazzo)

SECTION 09

SAND CUSHION TERRAZZO

Minimum of 2-1/2 inches thick (1/2 inch nominal terrazzo topping, 2 inch nominal underbed includes sand dusting on concrete substrate.) See Architectural Details.

PART 1 - GENERAL

1.01 RELATED WORK SPECIFIED IN OTHER SECTIONS

Note: Delete nonapplicable items.

- A. Furnishing and installation of metal lath and scratch coat, Section _____
- B. Attachment of metal stairs, any welding and/or reinforcing, Section _____
- C. Furnishing and setting floor drains, Section _____
- D. Furnishing and setting surface hardware, Section _____
- E. Setting of metal base beads and wood grounds, Section _____

Note: Delete where jurisdiction permits terrazzo contractor to install.

- F. Concrete subfloor, Section _____

Note: Subfloor shall not vary more than 1/4 inch from true plane in 10 foot span with float finish.

- G. Broom clean area to receive terrazzo of loose chips and all foreign matter.
- H. Sufficient water, temporary heat and light, and adequate electric power with suitable outlets connected and distributed for use within 100 feet of any working space.

Note: Ambient temperatures shall be maintained at minimum of 50 degrees Fahrenheit.

1.02 QUALITY ASSURANCE

- A. Acceptable Suppliers:
 - 1. Suppliers shall provide materials in accordance with the NTMA standards.
- B. Acceptable Installer:
 - 1. Installer shall be a contractor member of NTMA and shall perform all work in accordance with NTMA standards.
 - 2. If installer is not a contractor member of NTMA, installer shall submit a list of completed projects of similar magnitude and complexity.

1.03 SUBMITTAL

- A. Samples:
 - 1. Submit a maximum of three samples, sizes 6 inches x 6 inches for each color and type of terrazzo specified.
 - 2. Submit two, 6-inch lengths of each type and kind of divider strip as specified.
- B. Maintenance Literature:
 - 1. Submit two copies of NTMA maintenance recommendations.
- C. Certification:
 - 1. Suppliers shall furnish certification attesting that materials meet specification requirements.

1.04 DELIVERY, STORAGE AND HANDLING

- A. Delivery of Materials:
 - 1. Deliver materials in a manner to prevent damage to containers and/or bags.
- B. Storage of Materials:
 - 1. Store materials in a clean, dry, heated location furnished by others.

1.05 GUARANTEE

One year from date of completion of terrazzo installation.

PART 2 - PRODUCTS

2.01 MATERIALS

- A. Portland Cement: ASTM C 150, Color _____
Note: Select white or gray. White cement is uniform in color. Gray Portland cement may not be uniform in color and may produce a variation of shade in the matrix. (See Product Information.)
- B. Sand: Clean, washed, locally available sand.
- C. Marble Chips:
 - 1. Size: To conform with NTMA gradation standards.Note: See Product Information
 - 2. Abrasion and Impact resistance when testing in accordance with ASTM C 131-89 shall not exceed 40% loss.
 - 3. 24-hour absorption rate not to exceed 0.75%.
 - 4. Chips shall contain no deleterious or foreign matter.
 - 5. Dust content less than 1% by weight.
- D. Strips:
 - 1. Divider Strips _____ (gauge)
_____ (material)
with a depth of _____ (inches)
for a topping thickness of _____ (inches.)

Note: (See Divider Strips.) Select gauge, material, depth and topping thickness. Gauge: 18, 16, or 14 B & S gauge or 1/8, 1/4, or 3/8 inch heavy top. Material: White alloy of zinc, brass or plastic. Depth: 1-1/4 inches for 1/2 inch standard topping; 1-1/2 inches for a 3/4 inch Venetian topping.

Employment of the normal single divider strips, regardless of gauge, inserted in the Sand Cushion underbed up to five foot or less on centers, provide ample control of the anticipated shrinkage that will take place when the terrazzo work is installed in accordance to these specifications as each divider picks up a minute amount of the contraction. Construction joints in the structural slab have no bearing on the placement of divider strips in a Sand Cushion systems due to the use of an isolation membrane. Designed expansion plates are the responsibility of others to design, furnish and properly install in the event that they are required.

- E. Colorants: Alkali-resistant color stable pigments.
Note: Refer to NTMA Information Guide for further information.
- F. Reinforcement: ASTM A 185 16 or 18 gauge galvanized welded wire mesh.
- G. Isolation Membrane: ASTM D 2103 Type 13300, 4 mil. polyethylene sheeting or ASTM D 226, 15 pound unperforated roofing felt.
- H. Curing Materials: Water, wet sand, or polyethylene sheeting.
- I. Terrazzo Cleaner:
 - 1. Ph factor between 7 and 10, where applicable.
 - 2. Biodegradable and phosphate free.
- J. Sealer:
 - 1. Ph factor between 7 and 10, where applicable
 - 2. Shall not discolor or amber
 - 3. Penetrating type specially prepared for use on terrazzo.
 - 4. Flash Point: ASTM D 56, 80 degrees Fahrenheit minimum, where applicable.
 - 5. U/L listed as "Slip Resistant."

2.02 MIXES

- A. Terrazzo Selection:
 - 1. Type: _____
Note: Select type or types: Standard or Venetian.
 - 2. NTMA Plate # _____
Note: Select color and design from NTMA Information Guide or Color Plates. Any deviation from NTMA plates must be clearly stipulated.
- B. Proportions:
 - 1. Underbed: One part Portland cement to four parts sand and sufficient water to provide workability at as low a slump as possible.
 - 2. Terrazzo Topping: One 94 pound bag of Portland cement per 200 -pounds of marble chips, color pigment if required and sufficient potable water to produce a workable mix.
- C. Mixing:
 - 1. Underbed:
 - a. Charge and mix sand and Portland cement.
 - b. Add water and mix.
 - 2. Terrazzo Topping:
 - a. Charge and mix marble chips, Portland cement and color pigment if required.
 - b. Add water and mix to a uniform workable consistency.

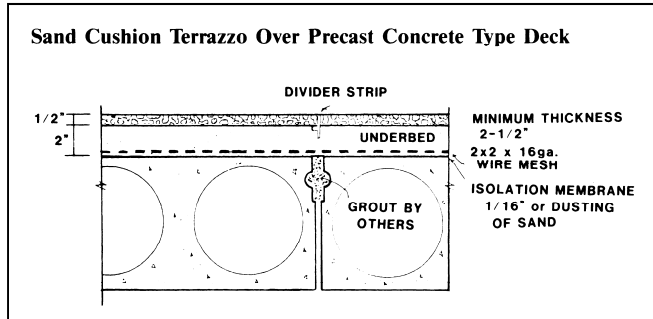
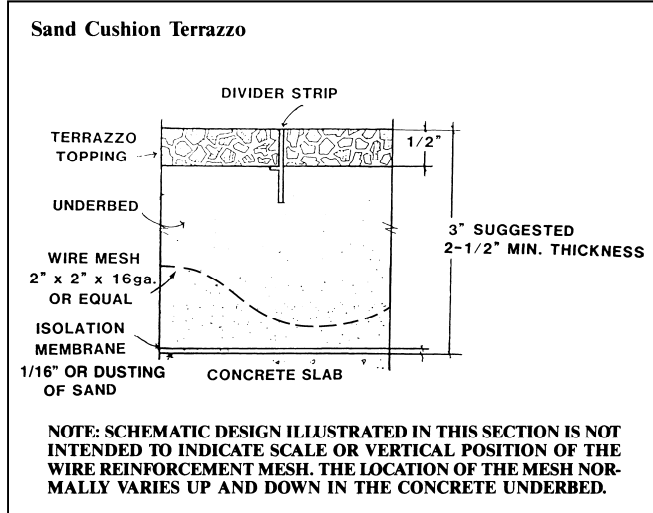

PART 3 - EXECUTION

3.01 INSPECTION

- A. Examine areas to receive terrazzo for:
 - 1. Defects in existing work that affect proper execution of terrazzo work.
 - 2. Deviations beyond allowable tolerances for the concrete slab work.
- B. Start work only when all defects have been corrected by others.

3.02 INSTALLATION

- A. Underbed:
 - 1. Cover entire surface to receive terrazzo with dusting of sand.
 - 2. Install isolation membrane overlapping ends and edges a minimum of 3 inches.
 - 3. Install welded wire reinforcement:
 - a. Overlap wire at edges and ends at least 2 squares.
 - 4. Place underbed mix.
 - 5. Screed underbed to elevation 1/2 inch below finished floor elevation or slope.
Note: Select 1/2 inch for standard topping or 3/4 inch for Venetian topping.
 - 6. Install divider strips as shown on drawings in semi-plastic underbed and trowel firmly along edges.
- B. Placing Terrazzo:
 - 1. Saturate underbed with water.
 - 2. Place terrazzo mixture in panels formed by divider strips and trowel mixture to top of strips.
 - 3. Seeding of additional marble chips is optional.
 - 4. Roll and compact surface until all excess cement and water has been extracted.
 - 5. Trowel to a dense uniform flat surface disclosing lines of divider strips.
- C. Curing:
 - 1. After completing placement of terrazzo and composition has sufficiently set, cover with water, wet sand or polyethylene sheeting.
 - 2. Cure until topping develops sufficient strength to prevent lifting or pulling of terrazzo chips during grinding.
- D. Finishing:
 - 1. Rough Grinding:
 - a. Grind with 24 or finer grit stones or with comparable diamond plates.
 - b. Follow initial grind with 80 or finer grit stones.
 - 2. Grouting:
 - a. Cleanse floor with clean water and rinse.

Terrazzo Specifications & Design Guide

- b: Remove excess rinse water and machine or hand apply grout, taking care to fill voids.
- 3. Cure grout:
 - Note: Grout may be left on terrazzo until all heavy and messy work on project is completed.*
- 4. Fine Grinding:
 - a: Grind with 80 or finer grit stones until all grout is removed from surface.
 - b: Upon completion, terrazzo shall show a minimum of 70% marble chips.
- E. Cleaning and Sealing:
 - 1. Wash all surfaces with a neutral cleaner.
 - 2. Rinse with clean water and allow surface to dry.
 - 3. Apply sealer in accordance with manufacturer's directions.
- F. Protection:
 - 1. Upon completion, the work shall be ready for final inspection and acceptance by the owner or his agent.
 - 2. The General Contractor shall protect the finished floor at the time that the Terrazzo Contractor completes the work.

GUIDE SPECIFICATION FOR BONDED TERRAZZO

(Revise 6/94 Supersedes all previous specifications for Bonded Terrazzo)

SECTION 09 BONDED TERRAZZO

Minimum of 1-3/4 inches thick (1/2 inch nominal topping thickness over 1-1/4 inch nominal underbed) See Architectural Details.

PART 1 - GENERAL

1.01 RELATED WORK SPECIFIED IN OTHER SECTIONS

Note: Delete nonapplicable items.

- A. Furnishing and installation of metal lath and scratch coat,
Section _____
- B. Attachment of metal stairs, any welding and/or reinforcing,
Section _____
- C. Furnishing and setting floor drains,
Section _____
- D. Furnishing and setting surface hardware,
Section _____
- E. Setting of metal base beads and wood grounds,
Section _____

Note: Delete where jurisdiction permits terrazzo contractor to install.

- F. Concrete subfloor,
Section _____

Note: Subfloor shall not vary more than 1/4 inch from true plane in 10 foot span with a broom finish free of laitance. No curing agents or other additives which could prevent bonding should be used. Saw cutting of control joints must be done between 12-24 hours after placement of the structural concrete.

- G. Broom clean area to receive terrazzo of loose chips and all foreign matter.
- H. Sufficient water, temporary heat and light, and adequate electric power with suitable outlets connected and distributed for use within 100 feet of any working space.

Note: Ambient temperatures shall be maintained at minimum of 50 degrees Fahrenheit.

1.02 QUALITY ASSURANCE

- A. Acceptable Suppliers:
 - 1. Suppliers shall provide materials in accordance with the NTMA standards.
- B. Acceptable Installer:
 - 1. Installer shall be a contractor member of NTMA and shall perform all work in accordance with NTMA standards.
 - 2. If installer is not a contractor member of NTMA, installer shall submit a list of completed projects of similar magnitude and complexity.

1.03 SUBMITTAL

- A. Samples:
 - 1. Submit a maximum of three samples, sizes 6 inches x 6 inches for each color and type of terrazzo specified.
 - 2. Submit two, 6-inch lengths of each type and kind of divider strip as specified.
- B. Maintenance Literature:
 - 1. Submit two copies of NTMA maintenance recommendations.
- C. Certification:
 - 1. Suppliers shall furnish certification attesting that materials meet specification requirements.

1.04 DELIVERY, STORAGE AND HANDLING

- A. Delivery of Materials:
 - 1. Deliver materials in a manner to prevent damage to containers and/or bags.
- B. Storage of Materials:
 - 1. Store materials in a clean, dry, heated location furnished by others.

1.05 GUARANTEE

One year from date of completion of terrazzo installation.

PART 2 - PRODUCTS

2.01 MATERIALS

- A. Portland Cement: ASTM C 150, Color _____
Note: Select white or gray. White cement is uniform in color. Gray Portland cement may not be uniform in color and may produce a variation of shade in the matrix. (See Product Information.)
- B. Sand: Clean, washed, locally available sand.
- C. Marble Chips:
 - 1. Size: To conform with NTMA gradation standards.
Note: See Product Information
 - 2. Abrasion and Impact resistance when testing in accordance with ASTM C 131-89 shall not exceed 40% loss.
 - 3. 24-hour absorption rate not to exceed 0.75%.
 - 4. Chips shall contain no deleterious or foreign matter.

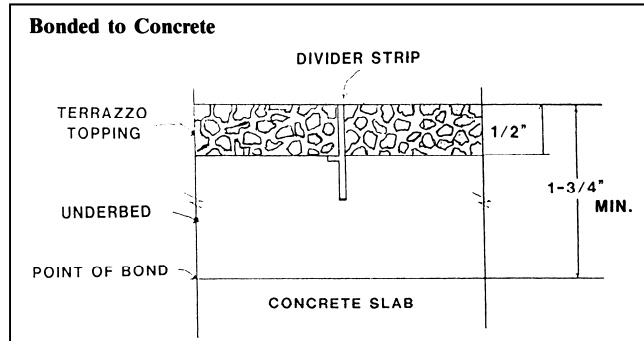

5. Dust content less than 1% by weight.
- D. Strips:
1. Divider Strips _____ (gauge)
_____ (material)
with a depth of _____ (inches)
for a topping thickness of _____ (inches.)
Note: (See Divider Strips.) Select gauge, material, and strip depth. Gauge: 18, 16, or 14 B & S gauge or 1/8, 1/4, or 3/8 inch heavy top. Material: White alloy of zinc, brass or plastic. Depth: 1-1/4 inches for 1/2 inch standard topping; 1- 1/2 inches for a 3/4 inch Venetian topping.
 2. Control Joint Strip: _____ (gauge)
_____ (material)
_____ (depth).
- NOTE: SELECT GAUGE AND DEPTH OF SOLID METAL STRIPS POSITIONING STRIPS BACK TO BACK WITH OR WITHOUT TEMPORARY FILLER AS REQUIRED. GAUGE 16 OR 14 B & S GAUGE. DEPTH 1-1/4".**
- E. Colorants: Alkali-resistant color stable pigments.
Note: Refer to NTMA Information Guide for further information.
- F. Curing Materials: Water, wet sand, or polyethylene sheeting.
- G. Terrazzo Cleaner:
1. Ph factor between 7 and 10, where applicable.
 2. Biodegradable and phosphate free.
- H. Sealer:
1. Ph factor between 7 and 10, where applicable.
 2. Shall not discolor or amber.
 3. Penetrating type specially prepared for use on terrazzo.
 4. Flash Point: ASTM D 56, 80 degrees Fahrenheit minimum, where applicable.
 5. U/L listed as "Slip Resistant".

2.02 MIXES

- A. Terrazzo Selection:
1. Type: _____
Note: Select type or types: Standard or Venetian.
 2. NTMA Plate # _____
Note: Select color and design from NTMA Information Guide or Color Palette. Any deviation from NTMA plates must be clearly stipulated.
- B. Proportions:
1. Underbed: One part Portland cement to four parts sand and sufficient water to provide workability at as low a slump as possible.
 2. Terrazzo Topping: One 94 pound bag of Portland cement per 200 - 220 pounds of marble chips, color pigment if required and sufficient potable water to produce a workable mix.
- C. Mixing:
1. Underbed:
 - a: Charge and mix sand and Portland cement.
 - b: Add water and mix.
 2. Terrazzo Topping:
 - a: Charge and mix marble chips, Portland cement and color pigment if required.
 - b: Add water and mix to a uniform workable consistency.

PART 3 - EXECUTION

3.01 INSPECTION

- A. Examine areas to receive terrazzo for:
1. Defects in existing work that affect proper execution of terrazzo work.
Note: Structural cracks in substrate will usually be transmitted through topping to surface.
 2. Deviations beyond allowable tolerances for the concrete slab work.
- B. Start work only when all defects have been corrected by others.

3.02 INSTALLATION

- A. Underbed:
1. Thoroughly saturate concrete subfloor with water, slush and broom neat cement paste.
 2. Place underbed mix.
 3. Screed underbed to elevation 1/2 inch below finished floor elevation or slope.
Note: Select 1/2 inch for standard topping or 3/4 inch for Venetian topping.
 4. Install divider strips as shown on drawings in semi-plastic underbed trowel firmly along edges.
 5. Install control joint strips back to back precisely above subfloor joints taking care that control joint is full depth of underbed.
- B. Placing Terrazzo:
1. Saturate underbed with water.
 2. Place terrazzo mixture in panels formed by divider strips and trowel mixture to top of strips.
 3. Seeding of additional marble chips is optional.
 4. Roll and compact surface until all excess cement and water has been extracted.
 5. Trowel to a dense uniform flat surface disclosing lines of divider strips.
- C. Curing:
1. After completing placement of terrazzo and composition has sufficiently set, cover with water, wet sand or polyethylene sheeting.
 2. Cure until topping develops sufficient strength to prevent lifting or pulling of terrazzo chips during grinding.
- D. Finishing:
1. Rough Grinding:
 - a: Grind with 24 or finer grit stones or with comparable diamond plates.
 - b: Follow initial grind with 80 or finer grit stones.

2. Grouting:
 - a: Cleanse floor with clean water and rinse.
 - b: Remove excess rinse water and machine or hand apply grout, taking care to fill voids.
3. Cure grout:

Note: Grout may be left on terrazzo until all heavy and messy work on project is completed.
4. Fine Grinding:
 - a: Grind with 80 or finer grit stones until all grout is removed from surface.
 - b: Upon completion, terrazzo shall show a minimum of 70% marble chips.
- E. Cleaning and Sealing:
 1. Wash all surfaces with a neutral cleaner.
 2. Rinse with clean water and allow surface to dry.
 3. Apply sealer in accordance with manufacturer's directions.
- F. Protection:
 1. Upon completion, the work shall be ready for final inspection and acceptance by the owner or his agent.
 2. The General Contractor shall protect the finished floor at the time that the Terrazzo Contractor completes the work.

GUIDE SPECIFICATION FOR MONOLITHIC TERRAZZO

(Revised 6/94 Supersedes all previous specifications for Monolithic Terrazzo)

MONOLITHIC TERRAZZO

1/2 inch nominal thickness.

PART 1 - GENERAL

1.01 RELATED WORK SPECIFIED IN OTHER SECTIONS

Note: Delete nonapplicable items.

- A. Furnishing and installation of metal lath and scratch coat,
Section _____
- B. Attachment of metal stairs, any welding and/or reinforcing,
Section _____
- C. Furnishing and setting floor drains,
Section _____
- D. Furnishing and setting surface hardware,
Section _____
- E. Setting of metal base beads and wood grounds,
Section _____

Note: Delete where jurisdiction permits terrazzo contractor to install.

- F. Concrete subfloor,
Section _____

Note: Concrete subfloor to be level (maximum variation not to exceed 1/4 inch in a 10 foot span) and to have a finely textured broom finish. No curing agents or other additives which could prevent bonding should be used. NOTE: Saw cutting of control joints must be done 12-24 hours after placement of the structural concrete.

- G. Broom clean area to receive terrazzo of loose chips and all foreign matter.
- H. Sufficient water, temporary heat and light, and adequate electric power with suitable outlets connected and distributed for use within 100 feet of any working space.

Note: Ambient temperatures shall be maintained at minimum of 50 degrees Fahrenheit.

1.02 QUALITY ASSURANCE

- A. Acceptable Suppliers:
 - 1. Suppliers shall provide materials in accordance with the NTMA standards.
- B. Acceptable Installer:
 - 1. Installer shall be a contractor member of NTMA and shall perform all work in accordance with NTMA standards.
 - 2. If installer is not a contractor member of NTMA, installer shall submit a list of completed projects of similar magnitude and complexity.

1.03 SUBMITTAL

- A. Samples:
 - 1. Submit a maximum of three samples, sizes 6 inches x 6 inches for each color and type of terrazzo specified.
 - 2. Submit two, 6-inch lengths of each type and kind of divider strip as specified.
- B. Maintenance Literature:
 - 1. Submit two copies of NTMA maintenance recommendations.
- C. Certification:
 - 1. Suppliers shall furnish certification attesting that materials meet specification requirements.

1.04 DELIVERY, STORAGE AND HANDLING

- A. Delivery of Materials:
 - 1. Deliver materials in a manner to prevent damage to containers and/or bags.
- B. Storage of Materials:
 - 1. Store materials in a clean, dry, heated location furnished by others.

1.05 GUARANTEE

One year from date of completion of terrazzo installation.

PART 2 - PRODUCTS

2.01 MATERIALS

- A. Portland Cement: ASTM C 150, Color _____
Note: Select white or gray. White cement is uniform in color. Gray Portland cement may not be uniform in color and may produce a variation of shade in the matrix. (See Product Information.)
- B. Marble Chips:
 - 1. Size: To conform with NTMA gradation standards.
Note: See Product Information
 - 2. Abrasion and Impact resistance when testing in accordance with ASTM C 131-89 shall not exceed 40% loss.
 - 3. 24-hour absorption rate not to exceed 0.75%.
 - 4. Chips shall contain no deleterious or foreign matter.

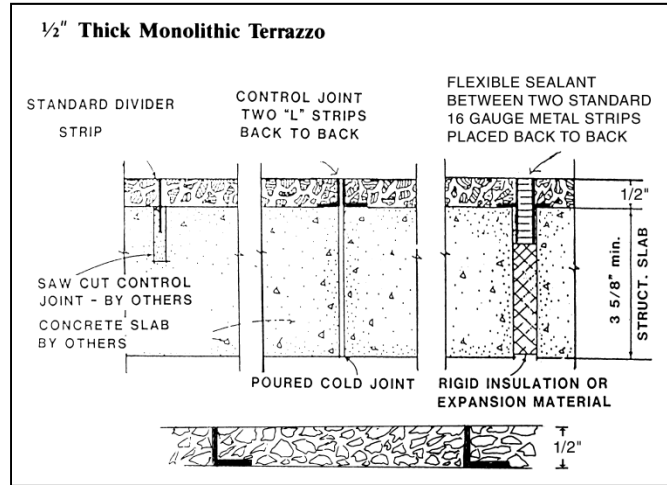

5. Dust content less than 1% by weight.
- C. Strips:
1. Divider Strips: _____ (gauge)
_____ (material)
with a depth of _____ (inches)
for a topping thickness of _____ (inches.)
- Note: (See Divider Strips.) Select gauge, material, depth and topping thickness. Gauge: 18, 16, or 14 B & S gauge or 1/8, 1/4, or 3/8 inch heavy top. Material: White alloy of zinc, brass or plastic. Depth: 1-1/4 inches for 1/2 inch standard topping; 1-1/2 inches for a 3/4 inch Venetian topping. K or L strips may be used for aesthetic reasons and are anchored by nailing or adhesive directly on subfloor.*
- D. Colorants: Alkali-resistant color stable pigments.
Note: Refer to NTMA Information Guide for further information.
- E. Bonding agents: Neat Portland cement, epoxy or acrylic.
- F. Curing Materials: Water, wet sand, or polyethylene sheeting.
- G. Terrazzo cleaner:
1. pH factor between 7 and 10, where applicable
 2. Biodegradable and phosphate free
- H. Sealer:
1. pH factor between 7 and 10, where applicable
 2. Shall not discolor or amber
 3. Penetrating type specially prepared for use on terrazzo.
 4. Flash Point: ASTM D 56, 80 degrees Fahrenheit minimum, where applicable.
 5. U/L Listed as "Slip Resistant."

2.02 MIXES

- A. Terrazzo Selection:
Note: Select type or types: Standard or Venetian.
NTMA Plate # _____
Note: Select color and design from NTMA Color Plates. Any deviation from NTMA plates must be clearly stipulated.
- B. Proportions:
1. Terrazzo Topping: One 94 pound bag of Portland cement per 200 - 220 pounds of marble chips, color pigment if required and sufficient potable water to produce a workable mix.
- C. Mixing:
1. Terrazzo Topping:
 - a: Charge and mix marble chips, Portland cement and color pigment if required.
 - b: Add water and mix to a uniform workable consistency.

PART 3 - EXECUTION

3.01 INSPECTION

- A. Examine areas to receive terrazzo for:
1. Defects in existing work that affect proper execution of terrazzo work.
NOTE: STRUCTURAL CRACKS IN SUBSTRATE WILL USUALLY BE TRANSMITTED THROUGH TOPPING TO SURFACE.
 2. Deviations beyond allowable tolerances for the concrete slab work.
- B. Start work only when all defects have been corrected by others.

3.02 INSTALLATION

- A. Subfloor:
1. Install control joints above control joints in subfloor.
 2. Install divider strips as shown on drawings.
- B. Placing Terrazzo:
1. Saturate concrete with water.
Note: Do not saturate concrete substrate with water if an epoxy bonding agent is used.
 2. Apply bonding agent.
Note: Synthetic bonding agent (acrylic or epoxy) may be considered.
 3. Place Terrazzo mixture in panels to top of strips.
 4. Seeding of additional marble chips is optional.
 5. Roll and compact surface until all excess cement and water has been extracted.
 6. Trowel to a uniform surface disclosing lines of divider strips.
- C. Curing:
1. After completing placement of terrazzo and composition has sufficiently set, cover with water, wet sand or polyethylene sheeting.
 2. Cure until topping develops sufficient strength to prevent lifting or pulling of terrazzo chips during grinding.
- D. Finishing:
1. Rough Grinding:
 - a: Grind with 24 or finer grit stones or with comparable diamond plates.
 - b: Follow initial grind with 80 or finer grit stones.
 2. Grouting:
 - a: Cleanse floor with clean water and rinse.
 - b: Remove excess rinse water and machine or hand apply grout, taking care to fill voids.
 3. Cure grout:
Note: Grout may be left on terrazzo until all heavy and messy work on project is completed.
 4. Fine Grinding:
 - a: Grind with 80 or finer grit stones until all grout is removed from surface.
 - b: Upon completion, terrazzo shall show a minimum of 70% marble chips.
- E. Cleaning and Sealing:
1. Wash all surfaces with a neutral cleaner.
 2. Rinse with clean water and allow surface to dry.

3. Apply sealer in accordance with manufacturer's directions.
- F. Protection:
1. Upon completion, the work shall be ready for final inspection and acceptance by the owner or his agent.
 2. The General Contractor shall protect the finished floor at the time that the Terrazzo Contractor completes the work.

GUIDE SPECIFICATION FOR STRUCTURAL TERRAZZO

Structural system over granular fill

(Revised 9/94 - supersedes all previous Specifications)

SECTION 09

STRUCTURAL TERRAZZO

Structural Terrazzo, both concrete substrate slab and terrazzo topping are provided by terrazzo installer. Minimum thickness of combination of substrate slab and terrazzo topping should be 5 inches.

PART 1-GENERAL

1.01 RELATED WORK SPECIFIED IN OTHER SECTIONS

NOTE: DELETE NONAPPLICABLE ITEMS.

- A. Excavation and site work including compacted granular fill to receive substrate slab.
Section _____
NOTE: GRANULAR FILL SPECIFICATIONS ARE DETERMINED BY PROJECT DESIGNER. HOWEVER, PERFORMANCE OF THE FILL IS RELATED TO THE PERFORMANCE OF THE TERRAZZO FINISH. FOLLOWING ARE RECOMMENDED MINIMUM SPECIFICATIONS FOR FILL: GRANULAR AND/OR SAND FILL COMPACTED TO 95% OF MAXIMUM DENSITY PER MODIFIED PROCTOR TEST ASTM D 1557-70.
- B. Provision of floor drains.
Section _____
- C. If required, provide enclosure with temporary heat maintained at minimum of 45 degrees Fahrenheit.
- D. Sufficient water, temporary heat and light, and adequate electric power with suitable outlets connected and distributed for use within 100 feet of any working space.

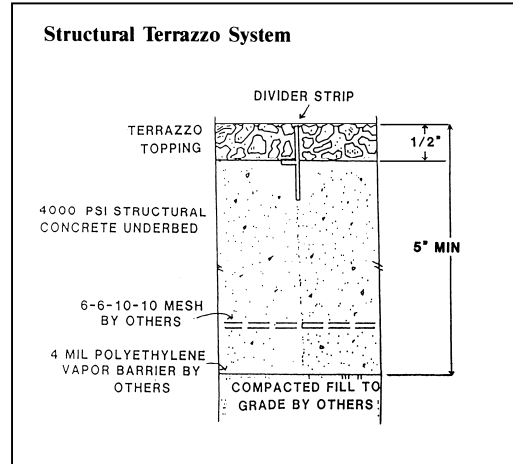

1.02 QUALITY ASSURANCE

- A. Acceptable supplier:
1. Materials furnished shall meet NTMA Specifications.
- B. Installer qualifications:
1. Installer shall be a contractor member of NTMA and shall perform work in accordance with NTMA standards.
2. If installer is not a contractor member of NTMA, installer shall submit a list of completed projects of a similar magnitude and complexity.

1.03 SUBMITTAL

- A. Samples:
1. Submit a maximum of three samples, minimum 6" x 6" for each color and type of Terrazzo.
2. Submit two, 6" minimum lengths of each type and kind of divider strips.
- B. Maintenance Literature:
1. Submit two copies of maintenance recommendations of NTMA or maintenance product members of NTMA.
- C. Certification:
1. Suppliers shall furnish certification attesting that materials meet specification requirements.

1.04 DELIVERY, STORAGE AND HANDLING

- A. Delivery of materials:
1. Deliver materials in a manner to prevent damage to containers and/or bags.
- B. Storage of materials:
1. Store materials in a clean, dry and heated (if necessary) location.

1.05 GUARANTEE

One year from date of substantial completion of Terrazzo installation.

PART 2-PRODUCTS

2.01 MATERIALS

- A. Portland cement: ASTM C 150, Color _____
NOTE: SELECT AND SPECIFY WHITE OR GRAY FOR TERRAZZO TOPPING. WHITE CEMENT IS UNIFORM IN COLOR. GRAY CEMENT MAY NOT BE UNIFORM IN COLOR AND MAY PRODUCE A VARIATION OF SHADE IN THE MATRIX.
- B. Sand: Coarse, clean, washed, locally available sand.
- C. Aggregate: 3/8" - 1/2" crushed stone.
- D. Marble Chips:
1. Size: Conform to NTMA gradation standards.
NOTE: SEE PRODUCT INFORMATION
2. Abrasion and Impact resistance when testing in accordance with ASTM C 131-89 shall not exceed 40% loss.
3. 24-Hour absorption rate not to exceed 0.75%.
4. Chips: Contain no deleterious or foreign matter.

5. Dust content less than 1% by weight.
- E. Strips:
1. Expansion joints: Plastic with a cap strip top with a depth of 1-1/4";
Thickness: _____ Color: _____
NOTE: SPECIFY MATERIAL AND SIZE. USE ETHAFOAM, BUTYL RUBBER OR CORK. 1/2" IS RECOMMENDED WIDTH, FULL DEPTH OF STRUCTURAL SLAB AND TOPPING. SEE STRIP GUIDE.
 2. Divider strips: _____
Materials: _____
Gauge: _____
Depth: _____
NOTE: SPECIFY MATERIAL TYPE AND GAUGE. STANDARDS ARE 1/8", 1/4", AND 3/8", WITH HEAVY TOP AND NON-CORROSIVE SOLID ZINC OR STAINLESS STEEL BOTTOM IN COLD WEATHER CLIMATES.
- F. Curing materials: 4-mil polyethylene sheeting or water.
- G. Sealant: Polyurethane with appropriate backer rod.
- H. Terrazzo Cleaner:
1. Ph factor between 7 and 10, where applicable.
 2. Biodegradable and phosphate free.
- I. Sealer:
1. Ph factor between 7 and 10, where applicable.
 2. Shall not discolor or amber.
 3. Penetrating type specially prepared for use on terrazzo.
 4. Flash Point: ASTM D 56, 80 degrees Fahrenheit minimum, where applicable.
 5. U/L Listed as "Slip Resistant."

2.02 MIXES

- A. NTMA Plate: _____
NOTE: SPECIFY COLOR AND DESIGN FROM NTMA COLOR PLATES. ANY DEVIATION FROM NTMA PLATE MUST BE CLEARLY STIPULATED.
- B. Proportions:
1. Concrete substrate: 3" maximum slump designed to exceed 4,000 psi 28 days after placement, but using no less than 6-1/2 bags of portland cement per cubic yard of concrete. Observe cold and warm weather pouring recommendation of American Concrete Institute.
NOTE: RECOMMENDED MIX: 3/8" TO 1/2" CRUSHED STONE, COURSE SAND, PORTLAND CEMENT AND CLEAN WATER.
 2. Terrazzo topping: One 94 pound bag of Portland Cement per 200-220 pounds of marble chips, color pigment if required and sufficient potable water to produce a workable mix.
- C. Mixing: Add aggregate, water, and portland cement in proper proportions, and mix thoroughly to uniform consistency. Maintain consistency by using same amount of water for all batches.

PART 3-EXECUTION

3.01 INSPECTION

- A. Examine areas to receive structural slab for defects in existing work that affect proper execution of the structural terrazzo work.
- B. Granular fill and/or sand fill must be within 1/2" plus or minus of required elevation and properly pitched to floor drains.
- C. Start work only when all defects have been corrected by others.

3.02 INSTALLATION:

- A. Concrete structural slab:
1. Set expansion material around building perimeter, around all column bases, and control joints lines indicated on the drawings, full depth of concrete structural slab.
NOTE: 1/2" WIDE, UNLESS OTHERWISE INDICATED, INSTALLED APPROXIMATELY 10' 0" x 10' 0" BUT NOT TO EXCEED 125 SQ. FT. OF INCLUDED AREAS.
 2. Place reinforcement wire at mid-depth of concrete slab.
 3. Place concrete and screed to an elevation of 1/2" to 3/4" below finished floor elevation, depending on size of aggregate used in topping.
 4. Install expansion joints and divider strips before concrete hardens.
 5. Roughen surface of concrete to broom finish to ensure bond of rustic terrazzo topping.
- B. Terrazzo topping:
- NOTE: 1/2" TO 3/4" THICKNESS DEPENDING ON SIZE OF AGGREGATE.
1. Soak substrate surface thoroughly with clean water.
 2. Place terrazzo.
 3. Roll and compact surface until all excess cement and water has been extracted.
 4. Trowel to a dense uniform flat surface disclosing lines of divider strips.
- C. Curing:
1. After completing placement of terrazzo and the composition has sufficiently set, cover with water, wet sand or polyethylene sheeting.
 2. Cure until topping develops sufficient strength to prevent lifting or pulling of terrazzo chips during grinding.
- D. Finishing:
1. Rough Grinding:
 - a. Grind with 24 or finer grit stones or with comparable diamond plates.
 - b. Follow initial grind with 80 grit or finer grit stones.
 2. Grouting:
 - a. Cleanse floor with clean water and rinse.
 - b. Remove excess rinse water and machine or hand apply grout, taking care to fill voids.
 3. Cure Grout:
NOTE: GROUT MAY BE LEFT ON TERRAZZO UNTIL ALL HEAVY AND MESSY WORK ON PROJECT IS COMPLETED.
 4. Fine Grinding:
 - a. Grind with 80 or finer grit stones until all grout is removed from surface.

Terrazzo Specifications & Design Guide

- b. Upon completion, terrazzo shall show a minimum of 70% marble chips.
- E. Cleaning and Sealing:
 - 1. Wash all surfaces with a neutral cleaner.
 - 2. Rinse with clean water and allow surface to dry.
 - 3. Apply sealer in accordance with manufacturer's directions.
- F. Protection:
 - 1. Upon completion, the work shall be ready for final inspection and acceptance by the owner or his agent.
 - 2. The General Contractor shall protect the finished floor from the time that the Terrazzo Contractor completes the work.

GUIDE SPECIFICATION FOR RUSTIC TERRAZZO

Structural system over granular fill

(Revised 6/94 - supersedes all previous Specifications)

SECTION 09 RUSTIC TERRAZZO

Rustic Terrazzo can utilize any cementitious terrazzo system. Most Rustic Terrazzo is installed on exterior, on-grade locations. NTMA considers the Structural System, Bonded or Unbonded System with underbed and Monolithic System suitable for this type of installation.

Structural System: in the Structural System, both concrete substrate slab and terrazzo topping are provided by terrazzo installer. Minimum thickness of combination of substrate slab and terrazzo topping should be 5 inches.

PART 1-GENERAL

1.01 RELATED WORK SPECIFIED IN OTHER SECTIONS

NOTE: DELETE NONAPPLICABLE ITEMS.

- A. Excavation and site work including compacted granular fill to receive substrate slab.
Section _____
NOTE: GRANULAR FILL SPECIFICATIONS ARE DETERMINED BY PROJECT DESIGNER. HOWEVER, PERFORMANCE OF THE FILL IS RELATED TO THE PERFORMANCE OF THE TERRAZZO FINISH.

FOLLOWING ARE RECOMMENDED MINIMUM SPECIFICATIONS FOR FILL:
GRANULAR AND/OR SAND FILL
COMPACTED TO 95% OF MAXIMUM DENSITY PER MODIFIED PROCTOR TEST ASTM D 1557-70.

- B. Concrete work other than specified herein.
Section _____
- C. Furnishing temporary power.
Section _____
- D. Furnishing clean water.
Section _____
- E. Provision of floor drains.
Section _____
- F. If required, provide enclosure with temporary heat maintained at a minimum of 45 degrees Fahrenheit.

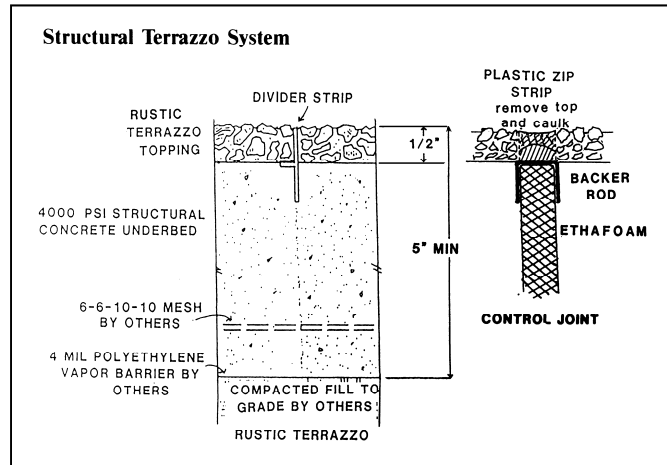

1.02 QUALITY ASSURANCE

- A. Acceptable supplier:
1. Materials furnished shall meet NTMA Specifications.
- B. Installer qualifications:
1. Installer shall be a contractor member of NTMA and shall perform all work in accordance with NTMA standards.
2. If installer is not a contractor member of NTMA, installer shall submit a list of completed projects of a similar magnitude and complexity.

1.03 SUBMITTAL

- A. Samples:
1. Submit a maximum of three samples, minimum 6" x 6" for each color and type of rustic terrazzo.
2. Submit two, 6" minimum lengths of each type and kind of divider strips.
- B. Maintenance Literature:
1. Submit two copies of maintenance recommendations of NTMA or maintenance product members of NTMA.
- C. Certification:
1. Suppliers shall furnish certification attesting that materials meet specification requirements.

1.04 DELIVERY, STORAGE AND HANDLING

- A. Delivery of materials:
1. Deliver materials in a manner to prevent damage to containers and/or bags.
- B. Storage of materials:
1. Store materials in a clean, dry and heated (if necessary) location.

1.05 GUARANTEE

One year from date of substantial completion of Terrazzo installation.

PART 2-PRODUCTS

2.01 MATERIALS

- A. Portland cement: ASTM C 150, Color _____
NOTE: SELECT AND SPECIFY WHITE OR GRAY FOR TERRAZZO TOPPING. WHITE CEMENT IS UNIFORM IN COLOR. GRAY CEMENT MAY NOT BE UNIFORM IN COLOR AND MAY PRODUCE A VARIATION OF SHADE IN THE MATRIX. WHERE CLIMACTIC CONDITIONS SO DEMAND, SPECIFY AN AIR ENTRAINING AGENT (6% AIR PLUS OR MINUS 1%) FOR STRUCTURAL SLAB TO MINIMIZE FREEZE-THAW CYCLE DAMAGE. PACKAGE AIR ENTRAINING CEMENT MUST NOT BE USED.
- B. Sand: Coarse, clean, washed, locally available sand.

- C. Aggregate: 3/8" - 1/2" crushed stone.
- D. Marble, Quartz, Granite and/or Gravel.
NOTE: SELECT HARD, DURABLE AGGREGATES, PARTICULARLY IN AREAS WHERE FREEZING OCCURS. CONSULT LOCAL TERRAZZO INSTALLER. IN AREAS SUCH AS SWIMMING POOLS DECKS, WHERE SMOOTHER FINISH MAY BE DESIRED, OVAL AGGREGATE SHOULD BE CONSIDERED.
 - 1. Size: Conform to NTMA standards.
 - 2. 24-hour absorption rate: Not to exceed 0.25%.
 - 3. Chips: Contain no deleterious or foreign matter.
- E. Strips:
 - 1. Expansion joints: Plastic with a cap strip top with a depth of 1-1/4"; Thickness: _____ Color: _____
NOTE: SPECIFY MATERIAL AND SIZE. USE ETHAFOAM, BUTYL RUBBER OR CORK. 1/2" IS RECOMMENDED WIDTH, FULL DEPTH OF STRUCTURAL SLAB AND TOPPING. SEE STRIP GUIDE.
 - 2. Divider strips: _____ Materials: _____
Gauge: _____ Depth: _____
NOTE: SPECIFY MATERIAL TYPE AND GAUGE. STANDARDS ARE 1/8", 1/4", AND 3/8", WITH HEAVY TOP AND NON-CORROSIVE SOLID ZINC OR STAINLESS STEEL BOTTOM IN COLD WEATHER CLIMATES.
- F. Curing materials: 4-mil polyethylene sheeting or water.
- G. Sealant: Polyurethane with appropriate backer rod.
- H. Sealer:
 - 1. Shall not discolor or amber.
 - 2. Penetrating type specifically prepared for use with rustic terrazzo.
NOTE: SOLVENT ACRYLIC TYPE PREFERRED.
- I. Reinforcing mesh 6" x 6" x 10 gauge minimum.
NOTE: OR AS DESIGNED FOR SPECIFIC SLAB LOAD REQUIREMENTS.

2.02 MIXES

- A. NTMA Plate: _____
NOTE: SPECIFY COLOR AND DESIGN FROM NTMA COLOR PLATES. ANY DEVIATION FROM NTMA PLATE MUST BE CLEARLY STIPULATED.
- B. Proportions:
 - 1. Concrete substrate: 3" maximum slump designed to exceed 4,000 psi 28 days after placement, but using no less than 6 1/2 bags of portland cement per cubic yard of concrete. Observe cold and warm weather pouring recommendation of American Concrete Institute.
NOTE: RECOMMENDED MIX: 3/8" TO 1/2" CRUSHED STONE, COURSE SAND, PORTLAND CEMENT, CLEAN WATER, AIR-ENTRAINING AGENT (6% AIR PLUS OR MINUS 1%), OR AS DESIGNED FOR SPECIFIC SLAB LOAD REQUIREMENTS TO ACHIEVE 4,000 PSI AT A 3" SLUMP.
 - 2. Terrazzo topping:
NOTE: RECOMMENDED MIX: ONE BAG (94 LBS) OF PORTLAND CEMENT PER 200 LBS OF AGGREGATE AND 4 1/2 TO 5 GALLONS OF CLEAN WATER. DEPTH OF TOPPING 1/2" TO 3/4", DEPENDING ON THE SIZE OF AGGREGATE. CLEAN WHITE FINE SAND MAY BE ADDED TO MIX.
- C. Mixing: Add aggregate, water, and portland cement in proper proportions, and mix thoroughly to uniform consistency. Maintain consistency by using same amount of water for all batches.

PART 3-EXECUTION

3.01 INSPECTION

- A. Examine areas to receive structural slab for defects in existing work that affect proper execution of the rustic terrazzo work.
- B. Granular fill and/or sand fill must be within 1/2" plus or minus of required elevation and properly pitched to floor drains.
- C. Start work only when all defects have been corrected by others.

3.02 INSTALLATIONS

- A. Concrete structural slab:
 - 1. Set expansion material around building perimeter, around all column bases, and control joints lines indicated on the drawings, full depth of concrete structural slab.
NOTE: 1/2" WIDE, UNLESS OTHERWISE INDICATED, INSTALLED APPROXIMATELY 10' 0" x 10' 0" BUT NOT TO EXCEED 125 SQ. FT. OF INCLUDED AREAS.
 - 2. Place reinforcement wire at mid-depth of concrete slab.
 - 3. Place concrete and screed to an elevation of 1/2" to 3/4" below finished floor elevation, depending on size of aggregate used in topping.
 - 4. Install expansion joints before concrete hardens.
 - 5. Roughen surface of concrete to broom finish to ensure bond of rustic terrazzo topping.
- B. Rustic terrazzo topping:
NOTE: 1/2" TO 3/4" THICKNESS DEPENDING ON SIZE OF AGGREGATE.
 - 1. Soak substrate surface thoroughly with clean water.
 - 2. Place rustic terrazzo.
 - 3. Roll and compact surface until all excess cement and water has been extracted.
- C. Finishing
 - 1. Expose aggregate by hosing, absorbent rolling, or use of a retarder.
- D. Curing:
 - 1. Flood with clean water, or cover with 4 mil. polyethylene sheeting.
- E. Cleaning:
 - 1. When topping is sufficiently cured, in the opinion of the terrazzo installer, apply a 1 to 10 solution of muriatic acid in water, scrub with a stiff broom to remove all laitance, and rinse immediately with clean water to remove all traces of the acid.
NOTE: ACID WASH NO SOONER THAN 7 DAYS AFTER INSTALLATION.
- F. Sealing:
 - 1. Rinse floor with clean water and allow to dry.
 - 2. When floor is dry, apply the sealer in accordance with manufacturer's directions for use on rustic terrazzo.
- G. Caulking:

Terrazzo Specifications & Design Guide

1. Place sealant in joints with backer rod as required.
- H. Protection:
1. Upon completion, the work shall be ready for final inspection and acceptance by the owner or his agent.
 2. The General Contractor shall protect the finished floor from the time that the rustic terrazzo installer completes the work.
- NOTE: COORDINATE WITH THE SPECIFICATIONS FOR PROTECTION IN SECTION 01600, "MATERIALS AND EQUIPMENT."*

IMPORTANT NOTE TO SPECIFIER FOR TRANSMITTAL TO OWNER OR OWNER'S AGENT: DE-ICING CHEMICAL AND SALT ARE INJURIOUS TO PORTLAND CEMENT SURFACES AND SHOULD NOT BE USED ON RUSTIC TERRAZZO.

*NOTE: SCHEMATIC DESIGN ILLUSTRATED IN THIS SECTION IS NOT INTENDED TO INDICATE SCALE OR VERTICAL POSITION OF THE WIRE REINFORCEMENT MESH. THE LOCATION OF THE MESH NORMALLY VARIES UP AND DOWN IN THE CONCRETE UNDERBED.

GUIDE SPECIFICATION FOR RUSTIC TERRAZZO

Bonded system with setting bed over concrete
(Revised 6/94 - supersedes all previous specifications)

SECTION 09 RUSTIC TERRAZZO

Rustic Terrazzo can utilize any cementitious terrazzo system. Most Rustic Terrazzo is installed on exterior, on-grade locations. NTMA considers the Structural System, Bonded or Unbonded Systems with underbed and monolithic System suitable for this type of installation.

Minimum thickness 1-3/4" Bonded System with setting bed over concrete substrate slab.

PART 1-GENERAL

1.01 RELATED WORK SPECIFIED IN OTHER SECTIONS

NOTE: DELETE NONAPPLICABLE ITEMS.

- A. Furnishing temporary power.
Section _____
- B. Furnishing clean water.
Section _____
- C. Structural Concrete slab to receive terrazzo topping.
Section _____

NOTE: SURFACE MUST NOT BE CURED WITH A LIQUID MEMBRANE OR CONTAINOTHER ADDITIVES WHICH COULD INHIBIT BOND OF TERRAZZO TOPPING.

- D. Expansion joints in concrete substrate slab.
- E. Provision of surface drains. Section _____
NOTE: SLAB MUST SLOPE A MINIMUM OF 1/8" PER FOOT TO OBTAIN PROPER DRAINAGE.

- F. If required, provide enclosure with temporary heat maintained at a minimum of 45 degrees Fahrenheit.

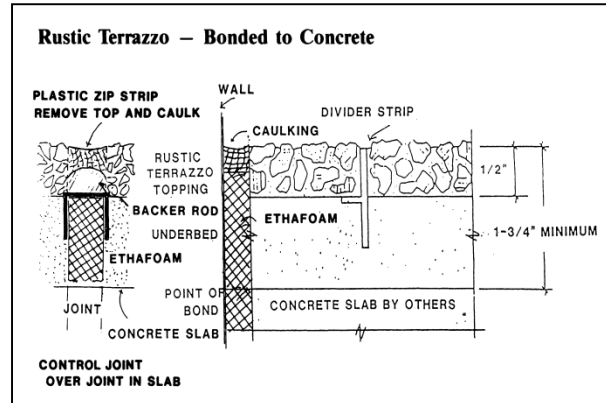

1.02 QUALITY ASSURANCE

- A. Acceptable supplier:
 - 1. Materials furnished shall meet NTMA Specifications.
- B. Installer qualifications:
 - 1. Installer shall be a contractor member of NTMA and shall perform all work in accordance with NTMA standards.
 - 2. If installer is not a contractor member of NTMA, installer shall submit a list of completed projects of a similar magnitude and complexity.

1.03 SUBMITTAL

- A. Samples:
 - 1. Submit a maximum of three samples, minimum 6" x 6" for each color and type of rustic terrazzo.
 - 2. Submit two, 6" minimum lengths of each type and kind of divider strips.
- B. Maintenance Literature:
 - 1. Submit two copies of maintenance recommendations of NTMA or maintenance product members of NTMA.
- C. Certification:
 - 1. Suppliers shall furnish certification attesting that materials meet specification requirements.

1.04 DELIVERY, STORAGE AND HANDLING

- A. Delivery of materials:
 - 1. Deliver materials in a manner to prevent damage to containers and/or bags.
- B. Storage of materials:
 - 1. Store materials in a clean, dry and heated (if necessary) location.

1.05 GUARANTEE

One year from date of substantial completion of Terrazzo installation.

PART 2-PRODUCTS

2.01 MATERIALS

- A. Portland cement: ASTM C 150, Color _____
NOTE: SELECT AND SPECIFY WHITE OR GRAY FOR TERRAZZO TOPPING. WHITE CEMENT IS UNIFORM IN COLOR. GRAYCEMENT MAY NOT BE UNIFORM IN COLOR AND MAY PRODUCE A VARIATION OF SHADE IN THE MATRIX. WHERE CLIMACTIC CONDITIONS DO DEMAND, SPECIFY AN AIR ENTRAINING AGENT (6% AIR PLUS OR MINUS 1%) FOR STRUCTURAL SLAB TO MINIMIZE FREEZE-THAW CYCLE DAMAGE. PACKAGE AIR ENTRAINING CEMENT MUST NOT BE USED.
- B. Sand: Coarse, clean, washed, locally available sand.
- C. Marble, Quartz, Granite and/or Gravel.
NOTE: SELECT HARD, DURABLE AGGREGATES, PARTICULARLY IN AREAS WHERE FREEZING OCCURS. CONSULT LOCAL TERRAZZO INSTALLER. IN AREAS SUCH AS SWIMMING POOLS DECKS, WHERE A SMOOTHER FINISH MAY BE DESIRED, OVAL AGGREGATE SHOULD BE CONSIDERED.
 - 1. Size: Conform to NTMA standards.

2. 24-hour absorption rate: Not to exceed 0.25%.
 3. Chips: Contain no deleterious or foreign matter.
- D. Strips:
1. Expansion joints: Plastic with a cap strip top with a depth of 1-1/4";
Thickness _____ Color: _____
NOTE: SPECIFY MATERIAL AND SIZE. USE ETHAFOAM, BUTYL RUBBER OR CORK. 1/2" IS RECOMMENDED WIDTH, FULL DEPTH OF UNDERBED AND TERRAZZO TOPPING. PLACE DIRECTLY ABOVE EXPANSION JOINTS IN CONCRETE STRUCTURAL SLAB. SEE STRIP GUIDE.
 2. Divider strips:
Materials _____ Gauge _____
- E. Curing materials: 4-mil polyethylene sheeting or water.
- F. Sealant: Polyurethane with appropriate backer rod.
- G. Sealer:
1. Shall not discolor or amber.
 2. Penetrating type specifically prepared for use with rustic terrazzo.
NOTE: SOLVENT ACRYLIC TYPE PREFERRED.
 3. Flash point: ASTM D 56, 95 degrees Fahrenheit.
- H. Bonding Agent: Neat Portland Cement.

2.02 MIXES

- A. NTMA Plate: _____
NOTE: SPECIFY COLOR AND DESIGN FROM NTMA INFORMATION GUIDE COLOR PLATES. ANY DEVIATION FROM NTMA PLATE MUST BE CLEARLY STIPULATED.
- B. Proportions:
1. Underbed: One part portland cement to 4 parts course sand. Air entrainment agent (6% plus or minus 1% air).
 2. Terrazzo topping:
NOTE: RECOMMENDED MIX: ONE BAG (94 LBS) OF PORTLAND CEMENT PER 200 LBS OF AGGREGATE AND 4-1/2 TO 5 GALLONS OF CLEAN WATER. DEPTH OF TOPPING 1/2" TO 3/4", DEPENDING ON THE SIZE OF AGGREGATE. CLEAN WHITE FINE SAND MAY BE ADDED TO MIX.
- C. Mixing: Add aggregate, water, and portland cement in proper proportions, and mix thoroughly to uniform consistency. Maintain consistency by using same amount of water for all batches.

PART 3-EXECUTION

3.01 INSPECTION

- A. Examine areas to receive rustic terrazzo for:
1. Defects in existing work that affect proper execution of terrazzo work.
NOTE: STRUCTURAL CRACKS IN SUBSTRATE WILL USUALLY BE TRANSMITTED THROUGH TOPPING TO SURFACE.
 2. Deviations beyond allowable tolerances for the concrete slab work.
- B. Start work only when all defects have been corrected by others.

3.02 INSTALLATIONS

- A. Concrete underbed:
1. Set expansion material around building perimeter, around all column bases, and directly above expansion joints in concrete structural slab.
 2. Soak surface of concrete structural slab with clean water.
 3. Place concrete and screed to an elevation of 1/2" to 3/4" below finished surface, depending on size of aggregate.
 4. Install plastic divider strips before concrete hardens.
- B. Placing Rustic terrazzo topping:
NOTE: 1/2" TO 3/4" THICKNESS DEPENDING ON SIZE OF AGGREGATE.
1. Soak underbed surface thoroughly with clean water.
 2. Place rustic terrazzo.
 3. Roll and compact surface until all excess cement and water has been extracted.
- C. Finishing
1. Expose aggregate by hosing, absorbent rolling, or use of a retarder.
- D. Curing:
1. Flood with clean water, or cover with 4 mil. polyethylene sheeting.
- E. Cleaning:
1. When topping is sufficiently cured, in the opinion of the terrazzo installer, apply a 1 to 10 solution of muriatic acid in water, scrub with a stiff broom to remove all laitance, and rinse immediately with clean water to remove all traces of the acid.
NOTE: ACID WASH NO SOONER THAN 7 DAYS AFTER INSTALLATION.
- F. Sealing:
1. Rinse floor with clean water and allow to dry.
 2. When floor is thoroughly dry, apply the sealer in accordance with manufacturer's directions for use on rustic terrazzo.
- G. Caulking:
1. Place sealant in joints with backer rod as required.
- H. Protection:
1. Upon completion, the work shall be ready for final inspection and acceptance by the owner or his agent.
 2. The General Contractor shall protect the finished floor from the time that the rustic terrazzo installer completes the work.
NOTE: COORDINATE WITH THE SPECIFICATIONS FOR PROTECTION IN SECTION 01600, "MATERIALS AND EQUIPMENT."

IMPORTANT NOTE TO SPECIFIER FOR TRANSMITTAL TO OWNER OR OWNER'S AGENT: DE-ICING CHEMICALS AND SALT CAN BE INJURIOUS TO PORTLAND CEMENT SURFACES AND SHOULD NOT BE USED ON RUSTIC TERRAZZO.

GUIDE SPECIFICATION FOR MONOLITHIC RUSTIC TERRAZZO

Monolithic Rustic Terrazzo – Direct Bond to Concrete Slab

(Revised 6/94 Supersedes all previous specifications)

SECTION 09 RUSTIC TERRAZZO

Rustic Terrazzo can utilize any cementitious terrazzo system. Most Rustic Terrazzo is installed on exterior, on-grade locations. NTMA considers the Structural System, Bonded or Unbonded System with underbed and Direct bond system suitable for this type of installation.

Monolithic system 1/2" to 3/4" thickness to concrete substrate slab by others.

PART 1-GENERAL

1.01 RELATED WORK SPECIFIED IN OTHER SECTION

NOTE: DELETE NONAPPLICABLE ITEMS.

- A. Furnishing temporary power.
Section _____
- B. Furnishing clean water.
Section _____
- C. Structural concrete slab to receive terrazzo topping.
Section _____

- 1. Clean area to receive terrazzo of loose chips, laitance, and foreign matter. Concrete slab specification is determined by project designer. However, performance of the slab is related to the performance of the terrazzo finish.
- 2. Following is recommended minimum specification for slab:
 - a. Maximum 3" slump, designed to exceed 4,000 psi in 28 days after placement.
 - b. Finished 1/2" to 3/4" below finished floor elevation (depending on size of aggregate). Surface roughened to facilitate bond of topping. Broom finish with stiff broom to striate approximately 1/8" deep, 1/8" wide and 1/8" apart.
 - c. Surface must not be cured with a liquid membrane or contain other additives which could prevent bond of terrazzo topping.

- D. Expansion joints in concrete substrate slab.

Section _____
NOTE: INSTALLED AT BUILDING PERIMETER, AROUND ALL COLUMN BASES AND TO DIVIDE THE SLAB APPROXIMATELY 10' x 10' EACH WAY, BUT NOT TO EXCEED 125 SQUARE FEET OF INCLUDED AREA, FULL DEPTH OF THE CONCRETE AND SET FLUSH WITH THE TOP OF THE CONCRETE SLAB. JOINT MATERIAL: 1/2" THICK PREFORMED, NON-EXTRUDED, FIBER EXPANSION JOINT MATERIAL, OR SIMILAR COMPRESSIBLE MATERIAL. SAW CUTTING OF CONTROL JOINTS MUST BE DONE BETWEEN 12-24 HOURS AFTER PLACEMENT OF THE STRUCTURAL CONCRETE.

- E. Provision of floor drains.
Section _____
- F. If required, provide enclosure with temporary heat maintained at a minimum of 45 degrees Fahrenheit.

1.02 QUALITY ASSURANCE

- A. Acceptable supplier:
 - 1. Materials furnished shall meet NTMA Specifications.
- B. Installer qualifications:
 - 1. Installer shall be a contractor member of NTMA and shall perform all work in accordance with NTMA standards.
 - 2. If installer is not a contractor member of NTMA, installer shall submit a list of completed projects of a similar magnitude and complexity.

1.03 SUBMITTAL

- A. Samples:
 - 1. Submit a maximum of three samples, minimum 6" x 6" for each color and type of rustic terrazzo.
 - 2. Submit two, 6" minimum lengths of each type and kind of divider strips.
- B. Maintenance Literature:
 - 1. Submit two copies of maintenance recommendations of NTMA or maintenance product members of NTMA.
- C. Certification:
 - 1. Suppliers shall furnish certification attesting that materials meet specification requirements.

1.04 DELIVERY, STORAGE AND HANDLING

- A. Delivery of materials:
 - 1. Deliver materials in a manner to prevent damage to containers and/or bags.
- B. Storage of materials:
 - 1. Store materials in a clean, dry and heated (if necessary) location.

1.05 GUARANTEE

One year from date of substantial completion of Terrazzo installation.

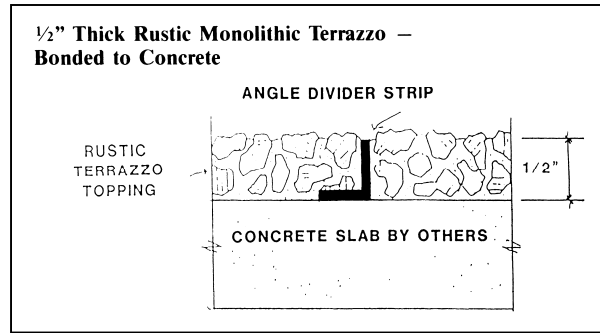

PART 2-PRODUCTS

2.01 MATERIALS

- A. Portland cement: ASTM C 150, Color _____
NOTE: SELECT AND SPECIFY WHITE OR GRAY FOR TERRAZZO TOPPING. WHITE CEMENT IS UNIFORM IN COLOR. GRAY CEMENT MAY NOT BE UNIFORM IN COLOR AND MAY PRODUCE A VARIATION OF SHADE IN THE MATRIX. WHERE CLIMATIC CONDITIONS SO DEMAND, SPECIFY AN AIR ENTRAINING AGENT (6% AIR PLUS OR MINUS 1%) FOR STRUCTURAL SLAB TO MINIMIZE FREEZE-THAW CYCLE DAMAGE. PACKAGE AIR ENTRAINING CEMENT MUST NOT BE USED.
- B. Marble, Quartz,, Granite and/or Gravel.
NOTE: SELECT HARD, DURABLE AGGREGATES, PARTICULARLY IN AREAS WHERE FREEZING OCCURS. CONSULT LOCAL TERRAZZO INSTALLER. IN AREAS SUCH AS SWIMMING POOL DECKS, WHERE A SMOOTHER FINISH MAY BE DESIRED, OVAL AGGREGATE SHOULD BE CONSIDERED.
1. Size: Conform to NTMA Standards.
2. 24-hour absorption rate; Not to exceed 0.75%.
3. Chips: Contain no deleterious or foreign matter
- C. Strips:
1. Expansion joints; Angle plastic material with a depth of 1/2" – 3/4";
Thickness: _____
Color: _____
or saw cuts, inserting straight strips into cuts.
NOTE: SPECIFY MATERIAL AND SIZE. USE ETHAFOAM, BUTYL RUBBER OR CORK. 1/2" IS RECOMMENDED WIDTH, FULL DEPTH OF TOPPING. PLACE DIRECTLY ABOVE EXPANSION JOINTS IN CONCRETE SUBSTRATE SLAB. SEE STRIP GUIDE.
2. Divider Strips:
Material _____
Gauge _____
- D. Curing materials: 4-mil polyethylene sheeting or water.
- E. Sealant: Polyurethane with appropriate backer rod.
- F. Sealer:
1. Shall not discolor or amber.
2. Penetrating type specifically prepared for use with rustic terrazzo.
NOTE: SOLVENT ACRYLIC TYPE PREFERRED.
3. Flash point: ASTM D 56, 95 degrees Fahrenheit.
- G. Bonding agents: Neat Portland Cement, epoxy or acrylic.

2.02 MIXES

- A. NTMA Plate: _____
NOTE: SPECIFY COLOR AND DESIGN FROM NTMA COLOR PLATE. ANY DEVIATION FROM NTMA PLATE MUST BE CLEARLY STIPULATED.
- B. Proportions:
1. Terrazzo topping:
NOTE: RECOMMENDED MIX: ONE BAG (94LB) OF PORTLAND CEMENT PER 200 LBS OF AGGREGATE AND 4-1/2 TO 5 GALLONS OF CLEAN WATER. DEPTH OF TOPPING 1/2" TO 3/4", DEPENDING ON SIZE OF AGGREGATE. CLEAN WHITE SAND MAY BE ADDED TO MIX.
- C. Mixing: Add aggregate, water, and portland cement in proper proportions, and mix thoroughly to uniform consistency. Maintain consistency by using same amount of water for all batches.

PART 3-EXECUTION

3.01 INSPECTION

- A. Examine areas to receive rustic terrazzo for:
1. Defects in existing work that affect proper execution of rustic terrazzo work.
2. Check concrete substrate for pitch to drains.
3. Check cleanliness of substrate slab.
- B. Start work only when all defect have been corrected by others.

3.02 INSTALLATION

- A. Set expansion joints at required thickness of topping.
- B. Placing rustic terrazzo topping:
1. Saturate concrete subfloor with clean water.
NOTE: DO NOT SATURATE CONCRETE SUBFLOOR WITH WATER IF AN EPOXY BONDING AGENT IS USED.
2. Apply bonding agent.
3. Place Rustic Terrazzo.
4. Roll and compact surface until all excess cement and water has been extracted.
- C. Finishing:
1. Expose aggregate by hosing, absorbent rolling, or use of a retarder.
- D. Curing:
1. Flood with clean water, or cover with 4-mil. polyethylene sheeting.
- E. Cleaning:
1. When topping is sufficiently cured, in the opinion of the terrazzo installer, apply a 1 to 10 solution of muriatic acid in water, scrub with a stiff broom to remove laitance, and rinse immediately with clean water to remove traces of the acid.
NOTE: ACID WASH NO SOONER THAN 7 DAYS AFTER INSTALLATION.
- F. Sealing:
1. Rinse floor with clean water and allow to dry.
2. When floor is thoroughly dry, apply the sealer in accordance with manufacturer's directions for use on rustic terrazzo.
- G. Protection:

Terrazzo Specifications & Design Guide

1. Upon substantial completion, the work shall be ready for final inspection and acceptance by the owner or his agent.
2. The General Contractor shall protect the finished floor from the time the rustic terrazzo installer completes the work.
NOTE: COORDINATE WITH THE SPECIFICATIONS FOR PROTECTION IN SECTION 01600, "MATERIALS AND EQUIPMENT".

IMPORTANT NOTE TO SPECIFIER FOR TRANSMITTAL TO OWNER OR OWNER'S AGENT: DE-ICING CHEMICALS AND SALT ARE INJURIOUS TO PORTLAND CEMENT SURFACES AND SHOULD NOT BE USED ON RUSTIC TERRAZZO.

GUIDE SPECIFICATION FOR UNBONDED RUSTIC TERRAZZO

Unbonded system with setting bed over concrete slab with waterproof membrane

(Revised 6/94 Supersedes all previous specifications)

SECTION 09 RUSTIC TERRAZZO

Rustic terrazzo can utilize any cementitious terrazzo system. Most Rustic terrazzo is installed on exterior, on-grade locations. NTMA considers the Structural System, Bonded or Unbonded System with underbed and Monolithic System suitable for this type of installation.

Minimum thickness 4 inches unbonded system with setting bed over waterproof concrete substrate slab.

PART 1-GENERAL

1.01 RELATED WORK SPECIFIED IN OTHER SECTIONS

NOTE: DELETE NONAPPLICABLE ITEMS

- A. Furnishing temporary power.
Section _____
- B. Furnishing clean water.
Section _____
- C. Structural concrete slab to receive terrazzo topping.
Section _____
- D. Expansion joints in concrete substrate slab.
Section _____
- E. Provision of floor drains.
Section _____

NOTE: TYPE WITH WEEP HOLES TO DRAIN WATER FROM SUBSTRATE SLAB. WEEP HOLES MUST BE AT LEAST 1" IN DIAMETER. SLAB MUST SLOPE A MINIMUM OF 1/8" PER FOOT TO OBTAIN PROPER DRAINAGE.

- F. If required, provide enclosure with temporary heat maintained at a minimum of 45 degrees Fahrenheit.
- G. Concrete slab and waterproof membrane by others.

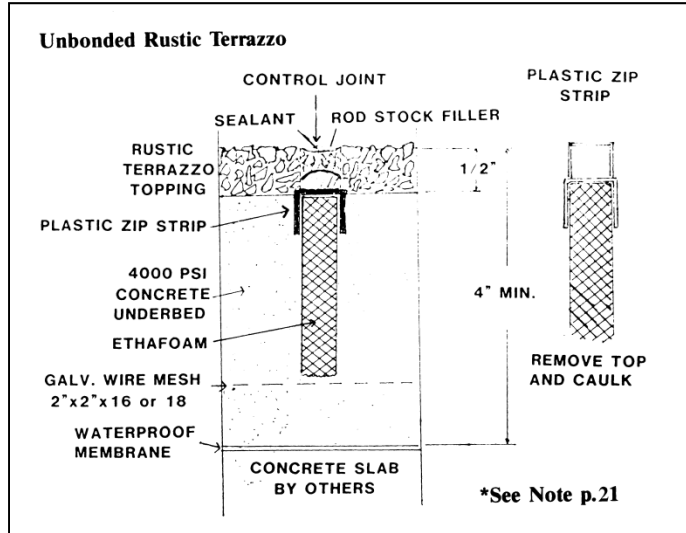

1.02 QUALITY ASSURANCE

- A. Acceptable supplier:
 - 1. Materials furnished shall meet NTMA Specifications.
- B. Installer qualifications:
 - 1. Installer shall be a contractor member of NTMA and shall perform all work in accordance with NTMA standards.
 - 2. If installer is not a contractor member of NTMA, installer shall submit a list of completed projects of a similar magnitude and complexity.

1.03 SUBMITTAL

- A. Samples:
 - 1. Submit a maximum of three samples, minimum 6" x 6" for each color and type of rustic terrazzo.
 - 2. Submit two, 6" minimum lengths of each type and kind of divider strips.
- B. Maintenance Literature:
 - 1. Submit two copies of maintenance recommendations of NTMA or maintenance product members of NTMA.
- C. Certification:
 - 1. Suppliers shall furnish certification attesting that materials meet specification requirements.

1.04 DELIVERY, STORAGE AND HANDLING

- A. Delivery of materials:
 - 1. Deliver materials in a manner to prevent damage to containers and/or bags.
- B. Storage of materials:
 - 1. Store materials in a clean, dry and heated (if necessary) location.

1.05 GUARANTEE

One year from date of substantial completion of Terrazzo installation.

PART 2-PRODUCTS

2.01 MATERIALS

- A. Portland cement: ASTM C 150, Color
NOTE: SELECT AND SPECIFY WHITE OR GRAY FOR TERRAZZO TOPPING. WHITE CEMENT IS UNIFORM IN COLOR. GRAY CEMENT MAY NOT BE UNIFORM IN COLOR AND MAY PRODUCE A VARIATION OF SHADE IN THE MATRIX. WHERE CLIMATIC CONDITIONS SO DEMAND, SPECIFY AN AIR ENTRAINING AGENT (6% AIR PLUS OR MINUS 1%)

FOR STRUCTURAL SLAB TO MINIMIZE FREEZE-THAW CYCLE DAMAGE. PACKAGE AIR ENTRAINING CEMENT MUST NOT BE USED.

- B. Sand: Coarse, clean, washed, locally available sand.
- C. Aggregate: 3/8" – 1/2" crushed stone.
- D. Marble, Quartz, Granite and/or Gravel.
NOTE: SELECT HARD, DURABLE AGGREGATES, PARTICULARLY IN AREAS WHERE FREEZING OCCURS. CONSULT LOCAL TERRAZZO INSTALLER. IN AREAS SUCH AS SWIMMING POOL DECKS, WHERE A SMOOTHER FINISH MAY BE DESIRED, OVAL AGGREGATE SHOULD BE CONSIDERED.
 - 1. Size: Conform to NTMA Standards.
 - 2. 24-hour absorption rate; Not to exceed 0.75%.
 - 3. Chips: Contain no deleterious or foreign matter.
- E. Strips:
 - 1. Expansion joints; Plastic with a cap strip top with a depth of 1-1/4";
Thickness: _____,
Color: _____,
or saw cuts, inserting straight strips into cuts.
NOTE: SPECIFY MATERIAL AND SIZE. USE ETHAFOAM, BUTYL RUBBER OR CORK. 1/2" IS RECOMMENDED WIDTH, FULL DEPTH OF TOPPING. PLACE DIRECTLY ABOVE EXPANSION JOINTS IN CONCRETE SUBSTRATE SLAB. SEE STRIP GUIDE.
 - 2. Divider Strips:
Material _____
Gauge _____
- F. Curing materials: 4-mil polyethylene sheeting or water.
- G. Sealant: Polyurethane with appropriate backer rod.
- H. Sealer:
 - 1. Shall not discolor or amber.
 - 2. Penetrating type specifically prepared for use with rustic terrazzo.
NOTE: SOLVENT ACRYLIC TYPE PREFERRED.
 - 3. Flash point: ASTM D 56, 95 Degrees Fahrenheit.
- I. Isolation Membrane: ASTM D 2103 Type 13300, 4 MIL. Polyethylene sheeting.
- J. Reinforcement: ASTM A 185, 2" x 2" x 16 Gauge or 18 gauge galvanized mesh.

2.02 MIXES

- A. NTMA Plate: _____
NOTE: SPECIFY COLOR AND DESIGN FROM NTMA COLOR PLATE. ANY DEVIATION FROM NTMA PLATE MUST BE CLEARLY STIPULATED.
- B. Proportions:
 - 1. Underbed: One part portland cement to 4 parts course sand. Air entrainment agent (6% plus or minus 1%).
NOTE: RECOMMEND MIX: 3/8" – 1/2" CRUSHED STONE, COURSE SAND, PORTLAND CEMENT, CLEAN WATER, AIR ENTRAINMENT AGENT (6% AIR PLUS OR MINUS 1%) OR AS DESIGNED FOR SPECIFIC SLAB LOAD REQUIREMENTS TO ACHIEVE 4,000 PSI AT A 3" SLUMP.
 - 2. Terrazzo topping:
NOTE: RECOMMENDED MIX: ONE BAG (94 LBS) OF PORTLAND CEMENT PER 200 LBS OF AGGREGATE AND 4-1/2 TO 5 GALLONS OF CLEAN WATER. DEPTH OF TOPPING 1/2" TO 3/4", DEPENDING ON THE SIZE OF AGGREGATE. CLEAN WHITE FINE SAND MAY BE ADDED TO MIX.
- C. Mixing: Add aggregate, water, and portland cement in proper proportions, and mix thoroughly to uniform consistency. Maintain consistency by using same amount of water for all batches.

PART 3-EXECUTION

3.01 INSPECTION

- A. Examine areas to receive terrazzo for defects in existing work that affect proper execution of Rustic Terrazzo.
- B. Check cleanliness of substrate.
- C. Start work only when all defects have been corrected by others.

3.02 INSTALLATION

- A. Concrete underbed:
 - 1. Set expansion material around building perimeter, around all column bases, and directly above expansion joints in concrete structural slab.
NOTE: 1/2" WIDE, UNLESS OTHERWISE INDICATED, INSTALLED APPROXIMATELY 10' x 10' BUT NOT TO EXCEED 125 SQ. FT. OF INCLUDED AREA.
 - 2. Place and screed to an elevation of 1/2" to 3/4" below finished surface, depending on size of aggregate.
 - 3. Install plastic divider strips before concrete hardens.
- B. Placing rustic terrazzo topping:
NOTE: 1/2" TO 3/4" THICKNESS DEPENDING ON SIZE OF AGGREGATE.
 - 1. Soak underbed surface with clean water.
 - 2. Place rustic terrazzo.
 - 3. Roll and compact surface until all excess cement and water has been extracted.
- C. Finishing:
 - 1. Expose aggregate by hosing, absorbent rolling, or use of a retarder.
- D. Curing:
 - 1. Flood with clean water, or cover with 4-mil polyethylene sheeting.
- E. Cleaning:
 - 1. When topping is sufficiently cured, in the opinion of the terrazzo installer, apply a 1 to 10 solution of muriatic acid in water, scrub with a stiff broom to remove laitance, and rinse immediately with clean water to remove traces of the acid.
NOTE: ACID WASH NO SOONER THAN 7 DAYS AFTER INSTALLATION.
- F. Sealing:
 - 1. Rinse floor with clean water and allow to dry.

Terrazzo Specifications & Design Guide

2. When floor is dry, apply the sealer in accordance with manufacturers directions for use on rustic terrazzo.
- G. Caulking:
1. Place sealant in joint with backer rod as required.
- H. Protection:
1. Upon completion, the work shall be ready for final inspection and acceptance by the owner or his agent.
 2. The General Contractor shall protect the finished floor from the time that the rustic terrazzo installer completes the work.
- NOTE: COORDINATE WITH THE SPECIFICATIONS FOR PROTECTION IN SECTION 01600, "MATERIAL AND EQUIPMENT"*

**NOTE: SCHEMATIC DESIGN ILLUSTRATED IN THIS SECTION IS NOT INTENDED TO INDICATE SCALE OR VERTICAL POSITION OF THE WIRE REINFORCEMENT MESH. THE LOCATION OF THE MESH NORMALLY VARIES UP AND DOWN IN THE CONCRETE UNDERBED.*

GUIDE SPECIFICATION FOR PALLADIANA

(Revised 6/94 Supersedes all previous Specifications for Palladiana)

SECTION 09 PALLADIANA

Minimum thickness of 1/2" topping can be installed as monolithic, bonded, or sand cushion. This specification is for the bonded system.

PART 1-GENERAL

1.01 RELATED WORK SPECIFIED IN OTHER SECTIONS

NOTE: DELETE NONAPPLICABLE ITEMS.

- A. Furnishing and/or installation of metal lath and scratch coat.

Section _____

- B. Attachment of metal stairs, any welding and/or reinforcing.

Section _____

- C. Furnishing and setting surface hardware.

Section _____

- D. Furnishing and setting floor drains,

Section _____

- E. Setting of metal base beads and wood ground,

Section _____

NOTE: DELETE IN CASES WHERE JURISDICTION PERMITS TERRAZZO CONTRACTOR TO INSTALL.

- F. Concrete subfloor, Section _____

NOTE: SUBFLOOR SHOULD NOT VARY MORE THAN 1/4" FROM TRUE PLANE IN 10 FOOT SPAN WITH A BROOM FINISH FREE OF LAITANCE. NO CURING AGENTS OR OTHER ADDITIVES WHICH COULD PREVENT BONDING SHOULD BE USED. SAW CUTTING OF CONTROL JOINTS MUST BE DONE BETWEEN 12-24 HOURS AFTER PLACEMENT OF THE STRUCTURAL CONCRETE.

- G. Broom clean area to receive Palladiana of loose chips, laitance and foreign matter.

- H. Sufficient water, temporary heat and light, and adequate electric with suitable outlets connected and distributed for use within 100 feet of any working space.

NOTE: AMBIENT TEMPERATURES SHALL BE MAINTAINED AT A MINIMUM OF 50 DEGREES FAHRENHEIT.

1.02 QUALITY ASSURANCE

- A. Acceptable supplier:

1. Materials furnished shall meet NTMA Specifications.

- B. Installer qualifications:

1. Installer shall be a contractor member of NTMA and shall perform all work in accordance with NTMA standards.

2. If installer is not a contractor member of NTMA, installer shall submit a list of completed projects of a similar magnitude and complexity.

1.03 SUBMITTAL

- A. Samples:

1. Submit a maximum of three samples, minimum 12" x 12" for each color and type of Palladiana specified.

2. Submit two, 6" minimum lengths of each type and kind of divider strips.

- B. Maintenance Literature:

1. Submit two copies of maintenance recommendations of NTMA or maintenance product members of NTMA.

- C. Certification:

1. Suppliers shall furnish certification attesting that materials meet specification requirements.

1.04 DELIVERY, STORAGE AND HANDLING

- A. Delivery of materials:

1. Deliver materials in a manner to prevent damage to containers and/or bags.

- B. Storage of materials:

1. Store materials in a clean, dry and heated (if necessary) location.

1.05 GUARANTEE

One year from date of substantial completion of Terrazzo installation.

PART 2-PRODUCTS

2.01 MATERIALS

- A. Portland cement:

ASTM C 150, Color _____

NOTE: SELECT AND SPECIFY WHITE OR GRAY FOR TERRAZZO TOPPING. WHITE CEMENT IS UNIFORM IN COLOR. GRAY CEMENT MAY NOT BE UNIFORM IN COLOR AND MAY PRODUCE A VARIATION OF SHADE IN THE MATRIX.

(See product information)

- B. Sand: Clean, washed, locally available sand.

- C. Fractured Marble Slabs:

1. Surface Dimension: Uniform 3/4 or 3/8 inch nominal thickness.

2. Abrasion and Impact resistance when testing in accordance with ASTM C 131-89 shall not exceed 40% loss.

- D. Strips:
1. Divider Strips: _____ (gauge)
_____ (material)
with a depth of _____ (inches)
for a topping thickness of _____ (inches).
NOTE: (SEE DIVIDER STRIPS) SELECT GAUGE, MATERIAL, STRIP DEPTH AND TOPPING THICKNESS. GAUGE: 18, 16, OR 14 B & S GAUGE OR 1/8, 1/4, OR 3/8 INCH HEAVY TOP. MATERIAL: WHITE ALLOY OF ZINC, BRASS OR PLASTIC.
 2. Control Joint Strip: _____ (gauge)
_____ (material)
_____ (depth).
NOTE: SELECT GAUGE AND DEPTH OF SOLID METAL STRIPS, POSITIONING STRIPS BACK TO BACK OR WITH OR WITHOUT TEMPORARY FILLER AS REQUIRED. GAUGE: 16 OR 14 B & S GAUGE.
- E. Colorants: Alkali-resistant color stable pigments.
NOTE: REFER TO NTMA INFORMATION GUIDE FOR FURTHER INFORMATION.
- F. CURING MATERIAL: WATER, WET SAND, OR POLYETHYLENE SHEETING.
- G. TERRAZZO CLEANER:
1. Ph factor between 7 and 10, where applicable.
 2. Biodegradable and phosphate free.
- H. Sealer:
1. Ph factor between 7 and 10, where applicable.
 2. Shall not discolor or amber.
 3. Penetrating type specially prepared for use on Palladiana.
 4. Flash Point: ASTM D 56, 80 degrees Fahrenheit minimum, where applicable.
 5. U/L listed as Slip Resistant.

2.02 MIXES

- A. Marble Selection:
1. Type: Palladiana.
 2. Marble Type: _____
NOTE: SELECT COLOR AND DESIGN FROM SAMPLES SUBMITTED BY TERRAZZO INSTALLER.
- B. Proportions:
1. Underbed: One part Portland cement to four parts sand and sufficient water to provide workability at as low a slump as possible.
 2. Palladiana Topping: Fractured marble slabs.
- C. Mixing:
1. Underbed:
 - a. Charge and mix sand and Portland cement.
 - b. Add water and mix.
 2. Palladiana Joints:
 - a. Charge and mix filler materials, Portland cement and color pigment, if required.
 - b. Add water and mix to a uniform workable consistency.

PART 3-EXECUTION

3.01 INSPECTION

- A. Examine areas to receive Palladiana for:
1. Defects in existing work that affect proper execution of Palladiana work.
 2. Deviations beyond allowable tolerances for the concrete slab work.
- B. Start work only when all defects have been corrected by others.

3.02 INSTALLATION

- A. Underbed:
1. Saturate concrete subfloor with water, slush and broom with neat cement paste.
 2. Place concrete underbed.
 3. Screed underbed to elevation as required for fractured marble slab thickness.
 4. Install control joint strips precisely above structural concrete joints taking care that control joint strip is full depth of underbed.
- B. Placing Palladiana:
1. Saturate underbed with water and apply neat cement slurry same color as specified for the joints.
 2. Broom slurry into underbed surface.
 3. Spread slurry on underside of fractured marble slabs.
 4. Place slabs and firmly bond to underbed to form even joints of about _____ inches between slabs.
NOTE: SELECT WIDTH OF JOINTS USUALLY ABOUT 3/8" TO 1-1/4 INCHES.
 5. Trowel filler mix into joints. Color as selected.
- C. Curing:
1. After completing placement of Palladiana, apply curing material, water, wet sand, polyethylene sheeting.
 2. Cure until topping develops sufficient strength to prevent lifting or pulling of Palladiana during grinding.
- D. Finishing:
1. Rough Grinding:
 - a. Grind with 60 or finer grit stones or with comparable diamond plates.
 - b. Follow initial grind with 120 or finer grit stones.
 2. Grouting:
 - a. Cleanse floor with water and rinse.
 - b. Remove excess rinse water and machine or hand apply grout, taking care of fill voids.
 3. Cure Grout:
NOTE: GROUT MAY BE LEFT OF PALLADIANA UNTIL ALL HEAVY AND MESSY WORK ON PROJECT IS COMPLETED.

- 4. Fine Grinding:
 - a. Grind with 220 or finer grit stones until all grout is removed from surface.
- E. Cleaning and Sealing:
 - 1. Wash all surfaces with a neutral cleaner.
 - 2. Rinse with clean water and allow surface to dry.
 - 3. Apply sealer in accordance with manufacturer's directions.
- F. Protection:
 - 1. Upon completion, the work shall be ready for final inspection and acceptance by the owner or his agent.
 - 2. The General Contractor shall protect the finished floor from the time the flooring contractor completes the work.

GUIDE SPECIFICATION FOR TERRAZZO OVER PERMANENT METAL FORMS

(Revised 6/94 Supersedes all previous Specifications for Terrazzo Over Metal Forms)

SECTION 09

TERRAZZO OVER PERMANENT METAL FORMS

Minimum thickness 3 inches from the point of the high ridge of the metal decking (1/2 inch Terrazzo topping with 2-1/2 inches of underbed).

PART 1-GENERAL

1.01 RELATED WORK SPECIFIED IN OTHER SECTIONS

NOTE: DELETE NONAPPLICABLE ITEMS.

- A. Furnishing and/or installation of metal lath and scratch coat.
Section _____
- B. Attachment of metal stairs, any welding and/or reinforcing.
Section _____
- C. Furnishing and setting surface hardware.
Section _____
- D. Furnishing and setting floor drains,
Section _____
- E. Setting of metal base beads and wood ground,
Section _____

NOTE: DELETE IN CASES WHERE JURISDICTION PERMITS TERRAZZO CONTRACTOR TO INSTALL.

- F. Clean area to receive Terrazzo of loose chips and all foreign matter.
- G. Sufficient water, temporary heat and light, and adequate electric with suitable outlets connected and distributed for use within 100 feet of any working space.
NOTE: AMBIENT TEMPERATURES SHALL BE MAINTAINED AT A MINIMUM OF 50 DEGREES FAHRENHEIT.
- H. Furnishing and setting reinforcement mesh,
Section _____
NOTE: 6 x 6 10-10 WELDED TO METAL FORMS 2 FEET APART AND ELEVATE 1/2" ABOVE METAL DECK AS DESIGNED BY ARCHITECT.

1.02 QUALITY ASSURANCE

- A. Acceptable supplier:
 - 1. Materials furnished shall meet NTMA Specifications.
- B. Installer qualifications:
 - 1. Installer shall be a contractor member of NTMA and shall perform all work in accordance with NTMA standards.
 - 2. If installer is not a contractor member of NTMA, installer shall submit a list of completed projects of a similar magnitude and complexity.

1.03 SUBMITTAL

- A. Samples:
 - 1. Submit a maximum of three samples, minimum 6" x 6" for each color and type of rustic terrazzo.
 - 2. Submit two, 6" minimum lengths of each type and kind of divider strips.
- B. Maintenance Literature:
 - 1. Submit two copies of maintenance recommendations of NTMA or maintenance product members of NTMA.
- C. Certification:
 - 1. Suppliers shall furnish certification attesting that materials meet specification requirements.

1.04 DELIVERY, STORAGE AND HANDLING

- A. Delivery of materials:
 - 1. Deliver materials in a manner to prevent damage to containers and/or bags.
- B. Storage of materials:
 - 1. Store materials in a clean, dry and heated (if necessary) location.

1.05 GUARANTEE

One year from date of substantial completion of Terrazzo installation.

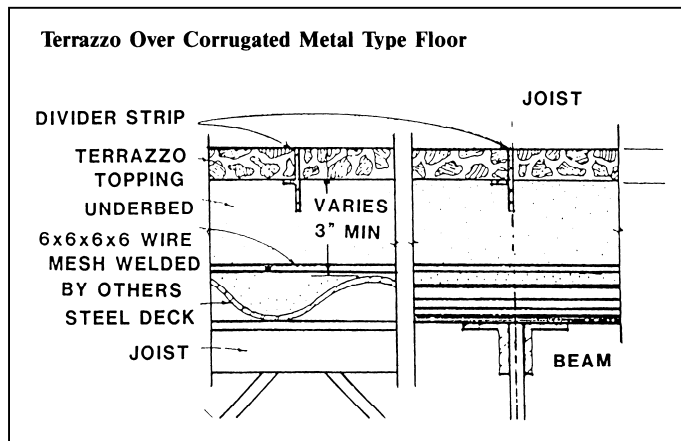
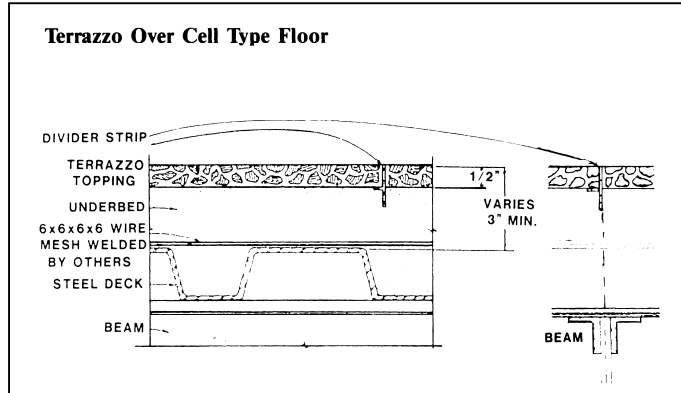

PART 2-PRODUCTS

2.01 MATERIALS

- A. Portland cement: ASTM C 150, Color _____
NOTE: SELECT AND SPECIFY WHITE OR GRAY FOR TERRAZZO TOPPING. WHITE CEMENT IS UNIFORM IN COLOR. GRAY PORTLAND CEMENT MAY NOT BE UNIFORM IN COLOR AND MAY PRODUCE A VARIATION OF SHADE IN THE MATRIX. (See product information)
- B. Sand: Clean, washed, locally available sand.
- C. Aggregate: 3/8" – 1/2" crushed stone.
- D. Marble Chips:
 - 1. Size to conform with NTMA gradation standards.*NOTE: SEE PRODUCT INFORMATION.*
 - 2. Abrasion and Impact resistance when testing in accordance with ASTM C 131-89 shall not exceed 40% loss.
 - 3. 24-Hour absorption rate not to exceed 0.75%.
 - 4. Chips shall contain no deleterious or foreign matter.
 - 5. Dust content less than 1% by weight.
- E. Strips:
 - 1. Divider Strips: _____ (gauge)
_____ (material)
with a depth of _____ (inches)
for a topping thickness of _____ (inches).
NOTE: (SEE DIVIDER STRIPS) SELECT GAUGE, MATERIAL, STRIP DEPTH. GAUGE: 18, 16 OR 14 B & S GAUGE OR 1/8, 1/4 OR 3/8 INCH HEAVY TOP. MATERIAL: WHITE ALLOY OF ZINC, BRASS OR PLASTIC. STRIP DEPTH: 1-1/4 INCHES FOR 1/2 INCH STANDARD TOPPING; 1-1/2 INCHES FOR A 3/4 INCH VENETIAN TOPPING.
- F. Colorants: Alkali-resistant color stable pigments.
NOTE: REFER TO NTMA INFORMATION GUIDE FOR FURTHER INFORMATION.
- G. Curing Material: WATER, WET SAND, OR POLYETHYLENE SHEETING.
 - 1. Ph factor between 7 and 10, where applicable.
 - 2. Biodegradable and phosphate free.
- I. Sealer:
 - 1. Ph factor between 7 and 10, where applicable.
 - 2. Shall not discolor or amber.
 - 3. Penetrating type specially prepared for use on terrazzo.
 - 4. Flash Point: ASTM D 56, 80 degrees Fahrenheit minimum, where applicable.
 - 5. U/L listed as "slip resistant".

2.02 MIXES

- A. Terrazzo Selection:
 - 1. Type: _____
NOTE: SELECT TYPE OR TYPES: STANDARD OR VENETIAN
 - 2. NTMA Plate # _____
NOTE: SELECT COLOR AND DESIGN FROM NTMA COLOR PLATES. ANY DEVIATION FROM NTMA PLATES MUST BE CLEARLY STIPULATED.
- B. Proportions:
 - 1. Underbed: Portland cement, sand, aggregate, and sufficient water to achieve 4,000 psi at a 3" slump.
NOTE: ALLOW UNDERBED TO CURE FOR 72 HOURS BEFORE PLACING TERRAZZO TOPPING.
 - 2. Terrazzo Topping: One 94 pound bag of Portland Cement per 200 - 220 pounds of marble chips, color pigment if required and sufficient potable water to produce a workable mix.
- C. Mixing:
 - 1. Underbed:
 - a. Charge and mix sand, aggregate and Portland cement.
 - b. Add water and mix.
 - 2. Terrazzo topping:
 - a. Charge and mix marble chips, Portland cement and color pigment, if required.
 - b. Add water and mix to a uniform workable consistency.

PART 3-EXECUTION

3.01 INSPECTION

- A. Examine areas to receive terrazzo for:
 - 1. Defects in existing work that affect proper execution of terrazzo.
 - 2. Deviations beyond allowable tolerances.
- B. Start work only when all defects have been corrected by others.

3.02 INSTALLATION

- A. Underbed:
 - 1. Place underbed over reinforcement mesh placed and anchored by others in Section _____
 - 2. Install divider strips in underbed over center of joints.
NOTE: SEE SECTION ON STRIPS, SELECT DESIRED SPACING NOT TO EXCEED 4 FEET.
 - 3. Install Strips precisely above all beam centers.
 - 4. Screen underbed to 1/2 inch below finished elevation.
NOTE: SELECT 1/2 INCH FOR STANDARD TOPPING OR 3/4 INCH OR VENETIAN TOPPING.
 - 5. Allow underbed to cure for a minimum of 72 hours before placing terrazzo topping.
- B. Placing Terrazzo:
 - 1. Saturate underbed with water.
 - 2. Place terrazzo mixture in panels formed by divider strips and trowel mixture to top of surface.
 - 3. Seeding of additional marble chips is optional.

Terrazzo Specifications & Design Guide

4. Roll and compact surface until all excess cement and water has been extracted.
 5. Trowel to dense uniform flat surface disclosing lines of divider strips.
- C. Curing:
1. After completing placement of terrazzo and the composition has sufficiently set, cover with water, wet sand or polyethylene sheeting.
 2. Cure until topping develops sufficient strength to prevent lifting or pulling of terrazzo chips during grinding.
- D. Finishing:
1. Rough Grinding:
 - a. Grind with 24 or finer grit stones or with comparable diamond plates.
 - b. Follow initial grind with 80 or finer grit stones.
 2. Grouting:
 - a. Cleanse floor with clean water and rinse.
 - b. Remove excess rinse water and machine or hand apply grout using identical Portland cement, color and pigments as used in topping, taking care to fill voids.
 3. Cure Grout:
 - a. Allow grout to cure.
NOTE: GROUT MAY BE LEFT ON TERRAZZO UNTIL FINE GRINDING WHICH SHOULD NOT BE SCHEDULED UNTIL ALL HEAVY AND MESSY WORK ON PROJECT IS COMPLETED.
 4. Fine Grouting:
 - a. Grind with 80 or finer grit stones until all grout is removed from surface.
 - b. Upon completion, terrazzo shall show a minimum of 70% marble chips.
- E. Cleaning and Sealing:
1. Wash all surfaces with a neutral cleaner.
 2. Rinse with clean water and allow surface to dry.
 3. Apply sealer in accordance with manufacturer's directions.
- F. Protection:
1. Upon completion, the work shall be ready for final inspection and acceptance by the owner or his agent.
 2. The General Contractor shall protect the finished floor from the time that the rustic terrazzo installer completes the work.

GUIDE SPECIFICATION FOR PRECAST TERRAZZO BASE

(Revised 6/94 Supersedes all previous Specifications for Precast Base)

SECTION 09

PART 1-GENERAL

1.01 RELATED WORK SPECIFIED IN OTHER SECTIONS.

NOTE: DELETE NONAPPLICABLE ITEMS.

- A. Furnishing and/or installation of metal lath and scratch coat.
Section _____
- B. Attachment of metal stairs, any welding and/or reinforcing.
Section _____
- C. Broom clean area to receive precast terrazzo base of all loose chips, laitance and foreign matter.
- D. Sufficient water, temporary heat and light, and adequate electric power with suitable outlets connected and distributed for use within 100 feet of any working space.
NOTE: AMBIENT TEMPERATURES SHALL BE MAINTAINED AT A MINIMUM OF 50 DEGREES FAHRENHEIT.
- E. Backing for precast terrazzo base must be cement board, concrete or concrete block.

1.02 QUALITY ASSURANCE

- A. Acceptable supplier:
 - 1. Materials furnished shall meet NTMA Specifications.
- B. Installer qualifications:
 - 1. Installer shall be a contractor member of NTMA and shall perform all work in accordance with NTMA standards.
 - 2. If installer is not a contractor member of NTMA, they shall submit a list of completed projects of a similar magnitude and complexity.

1.03 SUBMITTAL

- A. Shop Drawings:
 - 1. Submit shop drawings of all precast terrazzo base.
 - 2. Submit shop drawings for _____
NOTE: SPECIFY OTHER ITEMS REQUIRING DIMENSIONS.
- B. Samples:
 - 1. Submit a maximum of three samples, minimum 6" x 6" in for each color of terrazzo base.
 - 2. Submit two, 6" minimum lengths of each type and kind of divider strips.
- C. Maintenance Literature:
 - 1. Submit two copies of NTMA maintenance recommendations of NTMA or maintenance product members of NTMA.
- D. Certification:
 - 1. Suppliers shall furnish certification attesting that materials meet specification requirements.

1.04 DELIVERY, STORAGE AND HANDLING

- A. Delivery of materials:
 - 1. Deliver materials in a manner to prevent damage to containers and/or bags.
- B. Storage of materials:
 - 1. Store materials in a clean, dry and heated location (50-90 degrees temperature controlled) furnished by others.

1.05 GUARANTEE

One year from date of substantial completion of Terrazzo installation.

PART 2-PRODUCTS

2.01 PRODUCTS

- A. Portland cement: ASTM C 150, Color _____
NOTE: SELECT AND SPECIFY WHITE OR GRAY. WHITE CEMENT IS UNIFORM IN COLOR. GRAY PORTLAND CEMENT MAY NOT BE UNIFORM IN COLOR AND MAY PRODUCE A VARIATION OF SHADE IN THE MATRIX. (See product information)
- B. Sand: Clean, washed, locally available sand.
- C. Precast Terrazzo:
 - 1. Shape and size exactly as indicated on drawings.
NOTE: MINIMUM THICKNESS 3/4", COVE RADIUS 3/4".
- D. Terrazzo Cleaner:
 - 1. Ph factor between 7 and 10, where applicable.
 - 2. Biodegradable and phosphate free.
- E. Sealer:
 - 1. Ph factor between 7 and 10, where applicable.
 - 2. Shall not discolor or amber.
 - 3. Penetrating type specially prepared for use on Terrazzo.
 - 4. Flash Point: ASTM D 56, 80 degrees Fahrenheit minimum, where applicable.

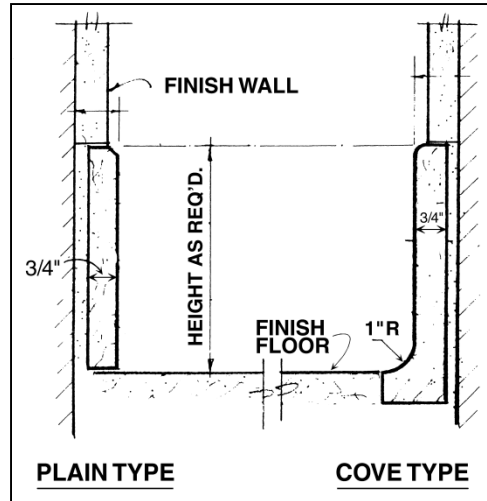

PART 3-EXECUTION

3.01 INSPECTION

- A. Examine areas to receive precast terrazzo for:
 - 1. Defects in existing work that affect proper execution of terrazzo work.
 - 2. Deviations beyond allowable tolerances for substrate work.
- B. Start work only when all defects have been corrected by others.

3.02 INSTALLATION

- A. Setting:
 - 1. Set accurately to wall and floor lines in setting bed prior to pouring terrazzo floors.
 - 2. Fill joints between precast base sections and clean off all excess grout.
- B. Protection:
 - 1. Upon completion, the work shall be ready for final inspection and acceptance by the owner or his agent.
 - 2. The General Contractor shall protect the finished work from the time that the terrazzo contractor completes the work.

GUIDE SPECIFICATION FOR POURED IN PLACE TERRAZZO BASE

(Revised 6/94 Supersedes all previous Specifications for Poured In Place Terrazzo Base)

SECTION 09

TERRAZZO BASE (POURED IN PLACE)

Where specified in conjunction with terrazzo floors include in terrazzo floor specification. This specification is written for Poured in Place Terrazzo Base ONLY.

PART 1-GENERAL

1.01 RELATED WORK SPECIFIED IN OTHER SECTIONS.

NOTE: DELETE NONAPPLICABLE ITEMS.

- A. Furnishing and/or installation of metal lath and scratch coat, Section _____
- B. Attachment of metal base beads and wood grounds Section _____
NOTE: DELETE IN CASES WHERE JURISDICTION PERMITS TERRAZZO CONTRACTOR TO INSTALL.
- C. Backing for cement terrazzo base must be cement board, or exterior grade plywood, concrete block, or cement plaster.
- D. Sufficient water, temporary heat and light, and adequate electric power with suitable outlets connected and distributed for use within 100 feet of any working space.
NOTE: AMBIENT TEMPERATURES SHALL BE MAINTAINED AT A MINIMUM OF 50 DEGREES FAHRENHEIT.

1.02 QUALITY ASSURANCE

- A. Acceptable supplier:
 - 1. Materials furnished shall meet NTMA Specifications.
- B. Installer qualifications:
 - 1. Installer shall be a contractor member of NTMA and shall perform all work in accordance with NTMA standards.
 - 2. If installer is not a contractor member of NTMA, they shall submit a list of completed projects of a similar magnitude and complexity.

1.03 SUBMITTAL

- A. Samples:
 - 1. Submit a maximum of three samples, minimum 6" x 6" for each color and type of terrazzo specified.
 - 2. Submit two, 6" minimum lengths of each type and kind of divider strip and/or control joint strip as specified.
- B. Maintenance Literature:
 - 1. Submit two copies of maintenance recommendations of NTMA or maintenance product members of NTMA.
- C. Certification:
 - 1. Suppliers shall furnish certification attesting that materials meet specification requirements.

1.04 DELIVERY, STORAGE AND HANDLING

- A. Delivery of materials:
 - 1. Deliver materials in a manner to prevent damage to containers and/or bags.
- B. Storage of materials:
 - 1. Store materials in a clean, dry and heated (if necessary) location.

1.05 GUARANTEE

One year from date of substantial completion of Terrazzo installation.

PART 2-PRODUCTS

2.01 MATERIALS

- A. Portland cement: ASTM C 150, Color _____
NOTE: SELECT AND SPECIFY WHITE OR GRAY FOR TERRAZZO TOPPING. WHITE CEMENT IS UNIFORM IN COLOR. GRAY CEMENT MAY NOT BE UNIFORM IN COLOR AND MAY PRODUCE A VARIATION OF SHADE IN THE MATRIX. (See product information)
- B. Sand: Clean, washed, locally available sand.
- C. Marble Chips:
 - 1. Size to conform with NTMA gradation standards.

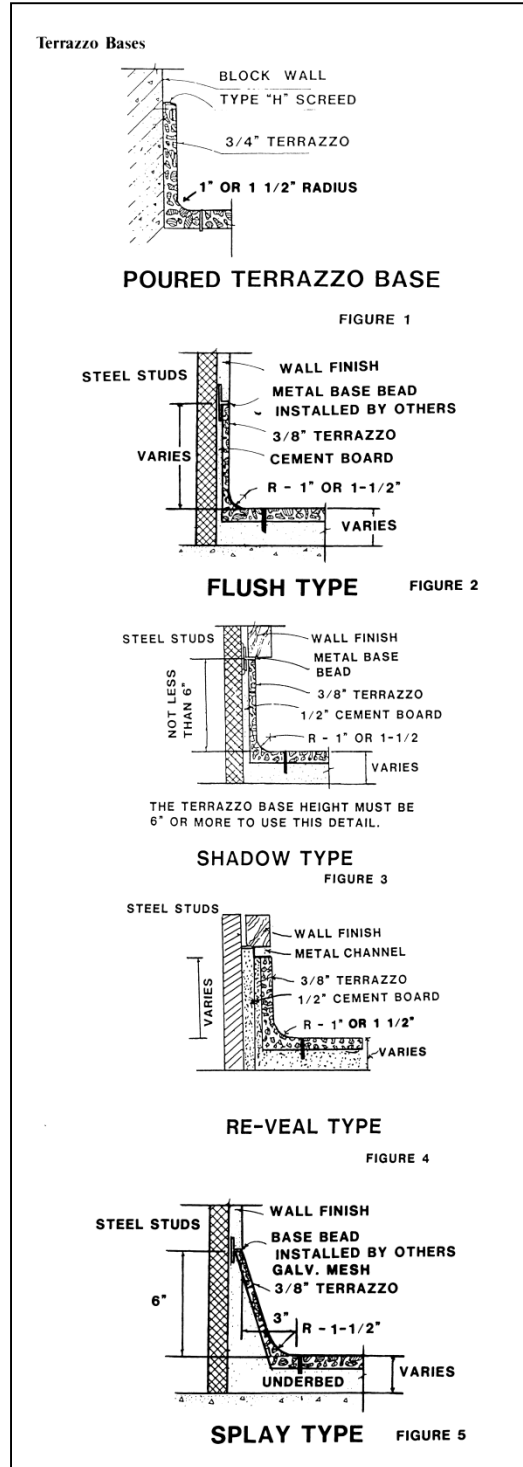

NOTE: SEE PRODUCT INFORMATION

2. Abrasion and Impact resistance when testing in accordance with ASTM C 131-89 shall not exceed 40% loss.
3. 24-Hour absorption rate not to exceed 0.75%.
4. Chips shall contain no deleterious or foreign matter.
5. Dust content less than 1% by weight.

D. Strips:

1. Divider Strips: _____ (gauge)
_____ (material)
with a height of _____ (inches) and a 1" or 1-1/2" radius cove.

*NOTE: (SEE DIVIDER STRIPS) SELECT GAUGE, HEIGHT, AND RADIUS OF COVE. GAUGE 18, 16, OR 14 B & S
GAUGE. MATERIAL: WHITE ALLOY OF ZINC, BRASS OR PLASTIC. HEIGHT: 4 OR 6 INCHES.* _____

E. Colorants: Alkali-resistant color stable pigments.

NOTE: REFER TO NTMA INFORMATION GUIDE FOR FURTHER INFORMATION.

F. TERRAZZO CLEANER:

1. Ph factor between 7 and 10, where applicable.
2. Biodegradable and phosphate free.

G. Sealer:

1. Ph factor between 7 and 10, where applicable.
2. Shall not discolor or amber.
3. Penetrating type specially prepared for use on Terrazzo.
4. Flash Point: ASTM D 56, 80 degrees Fahrenheit minimum, where applicable.

2.02 MIXES

A. Terrazzo Selection:

1. Type: _____
NOTE: COLOR AND DESIGN FROM NTMA INFORMATION GUIDE OR COLOR PLATE. _____

B. Proportions:

1. Setting bed: One part Portland cement to 3 part sand and sufficient water to provide workability at as low a slump as possible.
2. Terrazzo Topping: One 94 pound bag of Portland Cement per 125 pounds of marble chips, color pigment if required and sufficient potable water to produce a workable mix.

C. Mixing:

1. Setting Bed:
 - a. Charge and mix sand, aggregate and Portland cement.
 - b. Add water and mix.
2. Terrazzo topping:
 - a. Charge and mix marble chips, Portland cement and color pigment, if required.
 - b. Add water and mix to a uniform workable consistency.

PART 3-EXECUTION

3.01 INSPECTION

- A. Examine areas to receive terrazzo for defects in existing work that affect proper execution.
- B. Start work only when all defects have been corrected by others.

3.02 INSTALLATION

A. Setting Bed:

1. Apply mortar setting bed to backing.
2. Trowel setting bed to within 3/8" of finished wall line.
3. Install divider strips as shown on drawings in semi-plastic setting bed.

B. Placing Terrazzo:

1. Wet setting bed and apply neat cement slurry same color as specified for the topping including pigment if contained in topping.
2. Brush slurry into setting bed surface.
3. Trowel terrazzo mixture to base shape as detailed.

C. Finishing:

1. Rough Grinding:
 - a. Grind with 24 or finer grit stones or with comparable diamond plates.
 - b. Follow initial grind with 80 or finer grit stones.
2. Grouting:
 - a. Cleanse terrazzo with clean water and rinse.
 - b. Remove excess rinse water and hand apply grout using identical Portland cement, color pigments as used in topping, taking care to fill voids.
3. Cure Grout.
4. Fine Grinding:
 - a. Grind with 80 or finer grit stones until all grout is removed from surface.
 - b. Upon completion, terrazzo shall show a minimum of 70% of marble chips.

D. Cleaning and Sealing:

1. Wash all surfaces with a neutral cleaner.
2. Rinse with clean water and allow surface to dry.
3. Apply sealer in accordance with manufacturer's directions.

E. Protection:

1. Upon completion, the work shall be ready for final inspection and acceptance by the owner or his agent.
2. The General Contractor shall protect the finished work from the time that the terrazzo contractor completes the work.

**GUIDE SPECIFICATION FOR PRECAST TERRAZZO,
STAIRS, COVE, OR STRAIGHT BASE, COPING, PLANTERS,
WINDOW SILLS AND ANY ITEMS SPECIFIED AS PRECAST TERRAZZO**

(Revised 6/94 Supersedes all previous Specifications for Precast Terrazzo)

SECTION 09

PART 1-GENERAL

1.01 RELATED WORK SPECIFIED IN OTHER SECTIONS.

NOTE: DELETE NONAPPLICABLE ITEMS.

- A. Installation of concrete substrate to receive precast terrazzo stairs,
Section _____
- B. Installation of metal stairs, either pan type or supporting tubular stringers,
Section _____
- C. Backup walls of metal lath or masonry to receive precast terrazzo items,
Section _____
- D. Sufficient water, temporary heat and light, and adequate electric power with suitable outlets connected and distributed use within 100 feet of any working space.
NOTE: AMBIENT TEMPERATURE SHALL BE MAINTAINED AT A MINIMUM OF 50 DEGREES FAHRENHEIT.
- E. Broom clean area to receive precast terrazzo of all loose chips, laitance, and all foreign matter.

1.02 QUALITY ASSURANCE

- A. Acceptable supplier:
 - 1. Materials furnished shall meet NTMA Specifications.
- B. Installer qualifications:
 - 1. Installer shall be a contractor member of NTMA and shall perform all work in accordance with NTMA standards.
 - 2. If installer is not a contractor member of NTMA, installer shall submit a list of completed projects of a similar magnitude and complexity.

1.03 SUBMITTAL

- A. Shop drawings:
 - 1. Submit shop drawings of all precast terrazzo items showing detail sections and profile of all precast items. Details shall show all reinforcing, and special hardware for fastening rails.
- B. Samples:
 - 1. Submit maximum of 3 samples, 6 x 6 in size for each color.
 - 2. Submit two copies of NTMA maintenance literature.
- C. Certification:
 - 1. Suppliers shall furnish certification attesting that materials meet specification requirements.

1.04 DELIVERY, STORAGE AND HANDLING

- A. Delivery of materials:
 - 1. Deliver materials in a manner to prevent damage to containers.
- B. Storage of materials:
 - 1. Store materials in a clean, dry and heated (if necessary) location.

1.05 GUARANTEE

One year from date of substantial completion of Terrazzo installation.

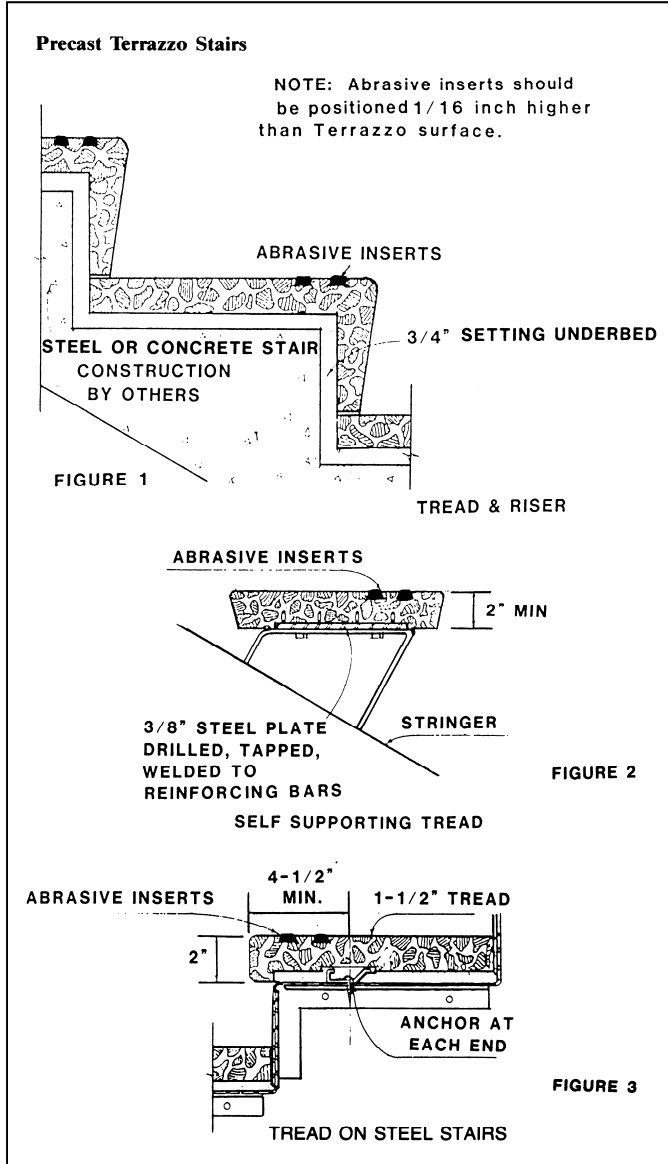

PART 2-PRODUCTS

2.01 PRODUCTS

- A. Portland cement: ASTM C 150, Color _____
NOTE: SELECT AND SPECIFY WHITE OR GRAY FOR TERRAZZO TOPPING. WHITE CEMENT IS UNIFORM IN COLOR. GRAY CEMENT MAY NOT BE UNIFORM IN COLOR AND MAY PRODUCE A VARIATION OF SHADE IN THE MATRIX. (See product information)
- B. Sand: Clean, washed, locally available sand.
- C. Marble Chips size to conform with NTMA gradation standards.
- D. Precast terrazzo:
 - 1. Shape and size exactly as indicated on drawings.
 - 2. Reinforce precast with deformed rods or wire mesh or both as recommended by precast terrazzo manufacturer.
 - 3. Abrasive safety lines shall be _____
NOTE: SPECIFY ONE TO THREE LINE ABRASIVE INSERTS.
- E. Terrazzo Cleaners:
 - 1. Ph factor between 7 and 10, where applicable.
 - 2. Biodegradable and phosphate free.
- F. Sealer:
 - 1. Ph factor between 7 and 10, where applicable.
 - 2. Shall not discolor or amber.
 - 3. Penetrating type specially prepared for use on terrazzo.
 - 4. Flash Point: ASTM D 56, 80 degrees Fahrenheit minimum, where applicable.

PART 3-EXECUTION

3.01 INSPECTION

- A. Examine areas to receive terrazzo for:
 - 1. Defects in existing work that affect proper execution of terrazzo.
 - 2. Deviations beyond allowable tolerances for the substrate.
- B. Start work only when all defects have been corrected by others.

3.02 INSTALLATION

- A. Setting:
 - 1. Set accurately as shown on approved shop drawings. Setting Methods are:
 - a. Mud set
 - b. Thin set
 - c. Weld
 - d. Bolt
 - 2. Alignment of precast should be straight and true to all dimensions. It may not vary more than 1/8" in length, height, or width.
 - 3. Install anchors as shown on details.
 - 4. Fill joints between sections with Portland Cement or caulking as per trade practice, or as specified.
- B. Protection:
 - 1. Upon completion, the work shall be ready for final inspection and acceptance by the owner or his agent.
 - 2. The General Contractor shall protect the finished work from the time that the terrazzo contractor completes the work.

RESTORATION OF TERRAZZO FINISH

Suggested Specifications — Refinishing Terrazzo Floors and Bases

- 1. Initial Grinding:
 - a. Grind with 24 or finer grit stone — fine mesh sand can be used if needed — all in the presence of water.
 - b. Follow initial grind with 80 or finer grit stones in the presence of water, but omit sand.
- 2. Grouting:
 - a. Cleanse floor with ample clean water and rinse.
 - b. Remove excess rinse water and machine or hand-apply grout, using a cement/acrylic, with or without color added to match the matrix of the Terrazzo floor, taking care to fill voids.
- 3. Curing Grout:
 - a. The grout shall remain on the surface for a minimum of 72 hours.
- 4. Fine Grinding:
 - a. Grind with 80 or finer grit stones until all grout has been removed from the Terrazzo surface.
- 5. Cleaning and Sealing:
 - a. Wash all surfaces with a neutral cleaner; follow by rinsing with clean water and allow to dry.
 - b. Apply one coat of sealer, as per manufacturer's directions.
- 6. Protection:

Upon completion, this work shall be ready for final inspection and acceptance by the owner or his agent. The General Contractor shall protect the finished floor from all trades that will follow.

(NOTE: All work mentioned above shall be executed with conventional terrazzo grinding equipment according to trade practice. No lighter type machines, such as floor scrubbing machines, will be accepted.)

GUIDE SPECIFICATION FOR POURED IN PLACE TERRAZZO STAIRS

(Revised 6/94 Supersedes all previous Specifications)

SECTION 09

TERRAZZO STAIRS (POURED IN PLACE)

Terrazzo stairs (poured in place): Where specified in conjunction with terrazzo floors include in terrazzo floor specification. This specification is written for Cast in Place Terrazzo Stairs only for concrete or steel substrates.

PART 1-GENERAL

1.01 RELATED WORK SPECIFIED IN OTHER SECTIONS

NOTE: DELETE NONAPPLICABLE ITEMS.

- A. Furnishing and/or installation of metal lath and scratch coat.
Section _____
- B. Attachment of metal stairs, any welding and mesh reinforcing.
Section _____
- C. Furnishing and setting surface hardware.
Section _____
- D. Setting of metal base beads and wood ground.
Section _____

NOTE: DELETE IN CASES WHERE JURISDICTION PERMITS TERRAZZO CONTRACTOR TO INSTALL.

- E. Backing for terrazzo base must be a cement board, concrete or concrete block.
Section _____
- F. Concrete subfloor, Section _____
NOTE: SUBFLOOR SHOULD NOT VARY MORE THAN 1/4" FROM TRUE PLANE IN A 10 FOOT SPAN WITH A BROOM FINISH FREE OF LAITANCE. NO CURING AGENTS OR OTHER ADDITIVES WHICH COULD PREVENT BONDING SHOULD BE USED.
- G. Broom clean area to receive terrazzo of loose chips, laitance and all foreign matter.
- H. Sufficient water, temporary heat and light, and adequate electric with suitable outlets connected and distributed for use within 100 feet of any working space.
NOTE: AMBIENT TEMPERATURES SHALL BE MAINTAINED AT A MINIMUM OF 50 DEGREES FAHRENHEIT.

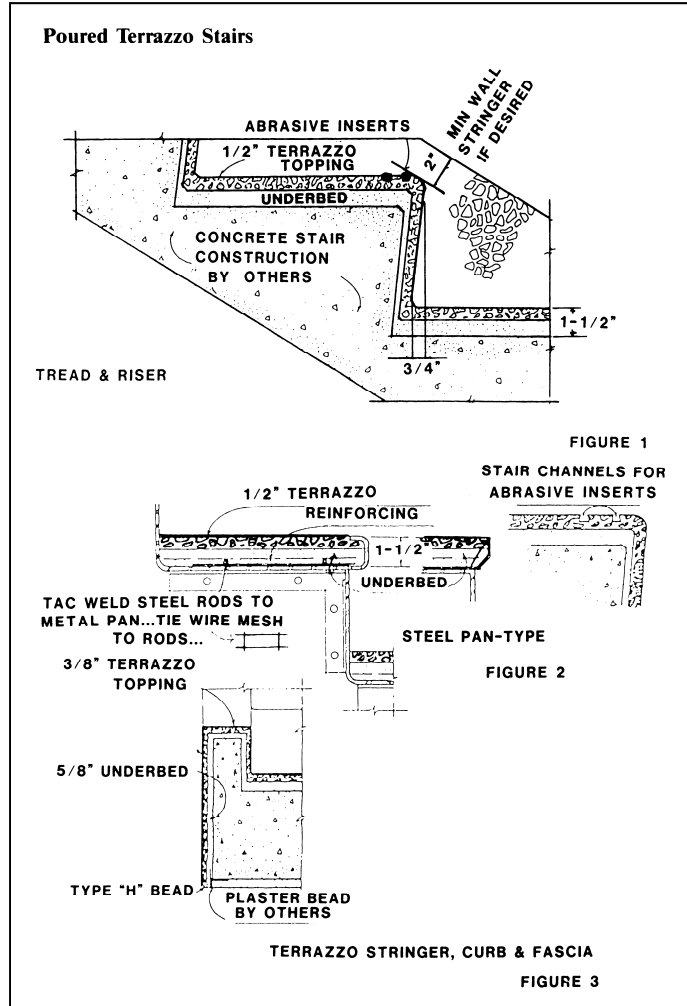

1.02 QUALITY ASSURANCE

- A. Acceptable supplier:
 - 1. Materials furnished shall meet NTMA Specifications.
- B. Installer qualifications:
 - 1. Installer shall be a contractor member of NTMA and shall perform all work in accordance with NTMA standards.
 - 2. If installer is not a contractor member of NTMA, installer shall submit a list of completed projects of a similar magnitude and complexity.

1.03 SUBMITTAL

- A. Samples:
 - 1. Submit a maximum of three samples, minimum 6" x 6" for each color and type of terrazzo.
 - 2. Submit two, 6" minimum lengths of each type and kind of divider strips.
- B. Maintenance Literature:
 - 1. Submit two copies of maintenance recommendations of NTMA or maintenance product members of NTMA.
- C. Certification:
 - 1. Suppliers shall furnish certification attesting that materials meet specification requirements.

1.04 DELIVERY, STORAGE AND HANDLING

- A. Delivery of materials:
 - 1. Deliver materials in a manner to prevent damage to containers and/or bags.
- B. Storage of materials:
 - 1. Store materials in a clean, dry and heated (if necessary) location.

1.05 GUARANTEE

One year from date of substantial completion of Terrazzo installation.

PART 2-PRODUCTS

2.01 MATERIALS

- A. Portland cement: ASTM C 150, Color _____
NOTE: SELECT AND SPECIFY WHITE OR GRAY FOR TERRAZZO TOPPING. WHITE CEMENT IS UNIFORM IN COLOR. GRAY CEMENT MAY NOT BE UNIFORM IN COLOR AND MAY PRODUCE A VARIATION OF SHADE IN THE MATRIX. (See product information)
- B. Sand: Clean, washed, locally available sand.
- C. Marble Chips:
 - 1. Size to conform with NTMA gradation standards.
NOTE: SEE PRODUCT INFORMATION.
 - 2. Abrasion and Impact resistance when testing in accordance with ASTM C 131-89 shall not exceed 40% loss.
 - 3. Abrasive safety lines shall be _____
NOTE: SPECIFY ONE LINE, TWO LINE, OR THREE LINE ABRASIVE INSERTS.
- D. Strips:
 - 1. Divider _____ (gauge)
_____ (material)
with a depth of _____ (inches)
for a topping thickness of _____ (inches).
NOTE: (SEE DIVIDER STRIPS) SELECT GAUGE, MATERIAL & STRIP DEPTH. GAUGE: 18, 16 OR 14 B & S GAUGE, OR 1/8, 1/4, OR 3/8 INCH HEAVY TOP. MATERIAL: WHITE ALLOY OF ZINC, BRASS OR PLASTIC. DEPTH: 1-1/4 INCHES FOR 1/2 INCH STANDARD TOPPING.
- E. Colorants: Alkali-resistant color stable pigments.
NOTE: REFER TO NTMA INFORMATION GUIDE FOR FURTHER INFORMATION.
- F. Curing Material: Water, Wet Sand, or Polyethylene Sheeting.
- G. TERRAZZO CLEANER:
 - 1. Ph factor between 7 and 10, where applicable.
 - 2. Biodegradable and phosphate free.
- H. Sealer:
 - 1. Ph factor between 7 and 10, where applicable.
 - 2. Shall not discolor or amber.
 - 3. Penetrating type specially prepared for use on Terrazzo.
 - 4. Flash Point: ASTM D 56, 80 degrees Fahrenheit minimum, where applicable.
 - 5. U/L listed as Slip Resistance.
- I. Abrasive strips: Carborundum or similar grit.
- J. Abrasive Strip Channel: 1/2" wide by 1/2" deep white alloy of zinc or brass.

2.02 MIXES

- A. Terrazzo Selection:
 - 1. Type: _____
NOTE: SELECT TYPE OR TYPES: STANDARD OR VENETIAN
 - 2. NTMA Plate # _____
NOTE: SELECT COLOR AND DESIGN FROM NTMA INFORMATION GUIDE OR COLOR PLATE. ANY DEVIATION FROM NTMA PLATES MUST BE CLEARLY STIPULATED.
- B. Proportions:
 - 1. Underbed: One part Portland cement to three parts sand and sufficient water to provide workability at as low a slump as possible.
 - 2. Terrazzo Topping: One 94 pound bag of Portland Cement per 125 pounds of marble chips, color pigment if required and sufficient potable water to produce a workable mix,
- C. Mixing:
 - 1. Underbed:
 - a. Charge and mix sand, aggregate and Portland cement.
 - b. Add water and mix.
 - 2. Terrazzo topping:
 - a. Charge and mix marble chips, Portland cement and color pigment, if required.
 - b. Add water and mix to a uniform workable consistency.

PART 3-EXECUTION

3.01 INSPECTION

- A. Examine areas to receive terrazzo for defects in existing work that affect proper execution of Terrazzo.
 - 1. Defects in existing work that affect proper execution of terrazzo.
 - 2. Deviations beyond allowable tolerances.
- B. Start work only when all defects have been corrected by others.

3.02 INSTALLATION

- A. Underbed:
 - 1. Thoroughly saturate concrete substrate with water, slush and broom with neat cement slurry.
NOTE: OVER STEEL SUBSTRATE, PLACE UNDERBED UNDER AND OVER MESH.
 - 2. Place concrete underbed.
 - 3. Screed underbed to 1/2 inch below finished elevation or slope.
 - 4. Install divider strips as shown on drawings in semi-plastic underbed.
 - 5. Position Abrasive Strip channels on stair treads as indicated on drawings.

- B. Placing Terrazzo:
 - 1. Slush underbed with neat cement slurry same color as specified for the topping.
 - 2. Broom slurry into underbed surface.
 - 3. Place terrazzo mixture in panels formed by divider strips on landings and on treads, risers, curbs and stringers as detailed. Trowel mixture to level of top of strips.
 - 4. Roll and compact surface until excess cement and water has been extracted.
 - 5. Trowel to a dense uniform flat surface disclosing lines of divider strips.
- C. Curing:
 - 1. After completing placement of terrazzo and composition has sufficiently set, cover with water, wet sand or polyethylene sheeting.
 - 2. Cure until topping develops sufficient strength to prevent lifting or pulling of terrazzo chips during grinding.
- D. Finishing:
 - 1. Rough Grinding:
 - a. Grind with 24 or finer grit stones or with comparable diamond plates.
 - b. Follow initial grind with 80 or finer grit stones.
 - 2. Grouting:
 - a. Cleanse terrazzo with clean water and rinse.
 - b. Remove excess rinse water and hand apply grout using identical Portland cement, color pigments as used in topping, taking care to fill voids.
 - 3. Cure Grout.
NOTE: GROUT MAY BE LEFT ON TERRAZZO UNTIL ALL HEAVY AND MESSY WORK IN PROJECT IS COMPLETED.
 - 4. Fine Grinding:
 - a. Grind with 80 or finer grit stones until all grout is removed from surface.
 - b. Upon completion, terrazzo shall show a minimum of 70% of marble chips.
- E. Abrasive Inserts:
 - 1. Carefully mask terrazzo on either side of abrasive channel to protect finished terrazzo.
 - 2. Clean all foreign matter from channel.
 - 3. Trowel abrasive mix into channel with finished elevation approximately 1/16" above terrazzo tread.
 - 4. Remove masking material and allow to cure.
 - 5. Prefabricated abrasive strips optional.
- F. Cleaning and Sealing:
 - 1. Wash all surfaces with a neutral cleaner.
 - 2. Rinse with clean water and allow surface to dry.
 - 3. Apply sealer in accordance with manufacturer's directions.
- G. Protection:
 - 1. Upon completion, the work shall be ready for final inspection and acceptance by the owner or his agent.
 - 2. The General Contractor shall protect the finished work from the time that the terrazzo contractor completes the work.

GUIDE SPECIFICATION FOR VERTICAL TERRAZZO

(Revised 6/94 Supersedes all previous Specifications for Vertical Terrazzo)

SECTION 09

VERTICAL TERRAZZO

Normally 1 inch thick (3/8" terrazzo topping).
(See architectural details)

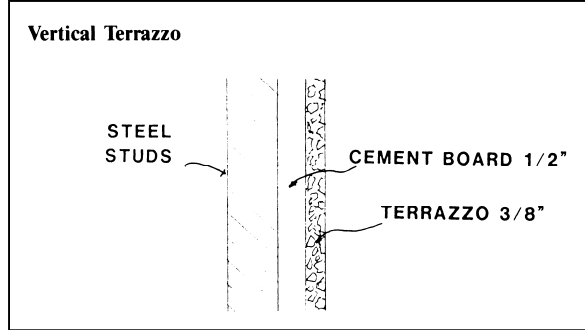

PART 1-GENERAL

1.01 RELATED WORK SPECIFIED IN OTHER SECTIONS

NOTE: DELETE NONAPPLICABLE ITEMS.

- A. Furnishing and/or installation of metal lath and scratch coat, Backing for terrazzo must be a cement board, concrete or concrete block.
Section _____

- B. Attachment of metal base beads and wood ground,
Section _____

NOTE: DELETE IN CASES WHERE JURISDICTION PERMITS TERRAZZO CONTRACTOR TO INSTALL.

- C. Sufficient water, temporary heat and light, and adequate electric with suitable outlets connected and distributed for use within 100 feet of any working space.

NOTE: AMBIENT TEMPERATURES SHALL BE MAINTAINED AT A MINIMUM OF 50 DEGREES FAHRENHEIT.

1.02 QUALITY ASSURANCE

- A. Acceptable supplier:
 - 1. Materials furnished shall meet NTMA Specifications.
- B. Installer qualifications:
 - 1. Installer shall be a contractor member of NTMA and shall perform all work in accordance with NTMA standards.
 - 2. If installer is not a contractor member of NTMA, they shall submit a list of completed projects of a similar magnitude and complexity.

1.03 SUBMITTAL

- A. Samples:
 - 1. Submit a maximum of three samples, minimum 6" x 6" for each color and type of terrazzo.
 - 2. Submit two, 6" minimum lengths of each type and kind of divider strips.
- B. Maintenance Literature:
 - 1. Submit two copies of maintenance recommendations of NTMA or maintenance product members of NTMA.
- C. Certification:
 - 1. Suppliers shall furnish certification attesting that materials meet specification requirements.

1.04 DELIVERY, STORAGE AND HANDLING

- A. Delivery of materials:
 - 1. Deliver materials in a manner to prevent damage to containers and/or bags.
- B. Storage of materials:
 - 1. Store materials in a clean, dry and heated (if necessary) location.

1.05 GUARANTEE

One year from date of substantial completion of Terrazzo installation.

PART 2-PRODUCTS

2.01 MATERIALS

- A. Portland cement: ASTM C 150, Color _____
NOTE: SELECT AND SPECIFY WHITE OR GRAY FOR TERRAZZO TOPPING. WHITE CEMENT IS UNIFORM IN COLOR. GRAY CEMENT MAY NOT BE UNIFORM IN COLOR AND MAY PRODUCE A VARIATION OF SHADE IN THE MATRIX. (See product information)
- B. Sand: Clean, washed, locally available sand.
- C. Marble Chips:
 - 1. Size to conform with NTMA gradation standards.
NOTE: SEE PRODUCT INFORMATION.
 - 2. Abrasion and Impact resistance when testing in accordance with ASTM C 131-89 shall not exceed 40% loss.
 - 3. 24-hour absorption rate not to exceed 0.75%.
 - 4. Chips shall contain no deleterious or foreign matter.
 - 5. Dust Content less than 1% by weight.
- D. Strips:
 - 1. Divider _____ (gauge)
_____ (material)
with a depth of _____ (inches)
for a topping thickness of _____ (inches).
NOTE: (See Divider Strips) Select gauge, material, and strip depth.

Terrazzo Specifications & Design Guide

- GUAGE:** 18, 16 OR 14 B & S gauge or 1/8, 1/4, or 3/8 - inch heavy top 1 inch depth.
- MATERIAL:** White alloy of zinc, brass or plastic.
- DEPTH OF TOPPING:** 3/8 inch for standard Terrazzo. K or L strips may be used for aesthetic reasons and are anchored by nailing or adhesive directly on substrate.

- E. Colorants: Alkali-resistant color stable pigments.
NOTE: REFER TO NTMA INFORMATION GUIDE FOR FURTHER INFORMATION.
- F. Curing Material: Water, or Polyethylene Sheeting.
- G. TERRAZZO CLEANER:
1. Ph factor between 7 and 10, where applicable.
2. Biodegradable and phosphate free.
- H. Sealer:
1. Ph factor between 7 and 10, where applicable.
2. Shall not discolor or amber.
3. Penetrating type specially prepared for use on Terrazzo.
4. Flash Point: ASTM D 56, 80 degrees Fahrenheit minimum, where applicable.
- I. Bonding Agent: Neat Portland Cement, Epoxy or Acrylic

2.02 MIXES

- A. Terrazzo Selection:
1. Type: _____

NOTE: SELECT COLOR AND DESIGN FOR NTMA INFORMATION GUIDE OR COLOR PLATES. ANY DEVIATION FROM NTMA PLATES MUST BE CLEARLY STIPULATED.

NOTE: SINCE DIFFERENT INSTALLATION TECHNIQUES ARE REQUIRED FOR VERTICAL TERRAZZO, IT MAY BE DIFFICULT OR IMPOSSIBLE TO MATCH EXACTLY THE FLOOR OR BASE COLOR. WHERE POSSIBLE, A DIFFERENT COLOR SHOULD BE SPECIFIED.

- B. Proportions:
1. Setting Bed: One part Portland cement to three parts sand and sufficient water to provide workability at as low a slump as possible.
2. Terrazzo Top: One 94 pound bag of Portland Cement per 125 pounds of marble chips, color pigment if required and sufficient potable water to produce a workable mix.
- C. Mixing:
1. Setting bed:
a. Charge and mix sand, aggregate and Portland cement.
b. Add water and mix.
2. Terrazzo topping:
a. Charge and mix marble chips, Portland cement and color pigment, if required.
b. Add water and mix to a uniform workable consistency.

PART 3-EXECUTION

3.01 INSPECTION

- A. Examine areas to receive terrazzo for defects in existing work that work that affect proper execution of Rustic Terrazzo.
1. Defects in existing work that affect proper execution of terrazzo.
- B. Start work only when all defects have been corrected by others.

3.02 INSTALLATION

- A. Setting Bed:
1. Apply bonding agent.
2. Apply mortar setting bed to backing.
3. Trowel setting bed to within 3/8" of finished wall line
4. Install divider strips as shown on drawings in semi-plastic setting bed.
NOTE: VERTICAL STRIPS SHOULD NOT EXCEED 72 INCHES ON CENTER.
- B. Placing Terrazzo:
1. Wet setting bed and apply neat cement slurry same color as specified for the topping including pigment if contained in topping.
2. Broom slurry into setting bed surface.
3. Apply terrazzo mixture in panels formed by divider strips and trowel mixture to top of strips.
4. Roll and compact surface until all excess cement and water has been extracted.
- C. Curing:
1. After completing placement of terrazzo, apply curing material.
2. Cure until topping develops sufficient strength to prevent lifting or pulling of marble chips during grinding.
- D. Finishing:
1. Rough Grinding:
a. Grind with 24 or finer grit stones or with comparable diamond plates.
b. Follow initial grind with 80 or finer grit stones.
2. Grouting:
a. Cleanse terrazzo with clean water and rinse.
b. Remove excess rinse water and hand apply grout using identical Portland cement, color pigments as used in topping, taking care to fill voids.
3. Cure Grout.
NOTE: GROUT MAY BE LEFT ON TERRAZZO UNTIL ALL HEAVY AND MESSY WORK IN PROJECT IS COMPLETED.
4. Fine Grinding:

Terrazzo Specifications & Design Guide

- a. Grind with 80 or finer grit stones until all grout is removed from surface.
 - b. Upon completion, terrazzo shall show a minimum of 70% of marble chips.
- E. Cleaning and Sealing:
- 1. Wash all surfaces with a neutral cleaner.
 - 2. Rinse with clean water and allow surface to dry.
 - 3. Apply sealer in accordance with manufacturer's directions.
- F. Protection:
- 1. Upon completion, the work shall be ready for final inspection and acceptance by the owner or his agent.
 - 2. The General Contractor shall protect the finished work from the time that the terrazzo contractor completes the work.

GUIDE SPECIFICATION FOR POLYACRYLATE MODIFIED TERRAZZO

(Revised 6/94 Supersedes all previous Specifications)

**SECTION 09
POLYACRYLATE MODIFIED TERRAZZO**
3/8 inch nominal thickness. Select thickness desired.

PART 1-GENERAL

1.01 RELATED WORK SPECIFIED IN OTHER SECTIONS

NOTE: DELETE NONAPPLICABLE ITEMS.

- A. Furnishing and/or installation of metal lath and scratch coat.
Section _____
- B. Attachment of metal stairs, any welding and mesh reinforcing.
Section _____
- C. Furnishing and setting of floor drains.
Section _____
- D. Furnishing and setting surface hardware.
Section _____
- E. Setting of metal base beads and wood ground.
Section _____

NOTE: DELETE IN CASES WHERE JURISDICTION PERMITS TERRAZZO CONTRACTOR TO INSTALL.

- F. Concrete subfloor, Section _____
NOTE: CONCRETE SUBFLOOR SHALL BE LEVEL (MAXIMUM VARIATION NOT TO EXCEED 1/4 INCH IN 10 FEET) AND SHALL HAVE A FINELY TEXTURED BROOM FINISH. NO CURING AGENTS OR OTHER ADDITIVES WHICH COULD PREVENT BONDING SHOULD BE USED. SAW CUTTING OF CONTROL JOINTS MUST BE DONE BETWEEN 12-24 HOURS AFTER PLACEMENT OF THE STRUCTURAL CONCRETE.
- G. Broom clean area to receive terrazzo of loose chips, laitance and all foreign matter.
- H. Sufficient water, temporary heat and light, and adequate electric with suitable outlets connected and distributed for use within 100 feet of any working space.
- I. Ambient and subfloor temperature shall be maintained at a minimum of 50 degrees Fahrenheit.

1.02 QUALITY ASSURANCE

- A. Acceptable supplier:
 - 1. Materials furnished shall meet NTMA Specifications.
- B. Installer qualifications:
 - 1. Installer shall be a contractor member of NTMA and shall perform all work in accordance with NTMA standards.
 - 2. If installer is not a contractor member of NTMA, installer shall submit a list of completed projects of a similar magnitude and complexity.

1.03 SUBMITTAL

- A. Samples:
 - 1. Submit a maximum of three samples, minimum 6" x 6" for each color and type of terrazzo.
 - 2. Submit two, 6" minimum lengths of each type and kind of divider strips.
- B. Maintenance Literature:
 - 1. Submit two copies of maintenance recommendations of NTMA or maintenance product members of NTMA.
- C. Certification:
 - 1. Suppliers shall furnish certification attesting that materials meet specification requirements.
 - 2. Supplier shall furnish properly labeled material and Material Safety Data Sheets which comply with current State or federal requirements.

1.04 DELIVERY, STORAGE AND HANDLING

- A. Delivery of materials:
 - 1. Deliver materials in a manner to prevent damage to containers and/or bags.
- B. Storage of materials:
 - 1. Store materials in a clean, dry and heated (if necessary) location.

1.05 GUARANTEE

One year from date of substantial completion of Terrazzo installation.

PART 2-PRODUCTS

2.01 MANUFACTURER MATERIAL LIST

- A. Primer: As recommended by Polyacrylate Resin Supplier.
- B. Polyacrylate Binder: Formulated to meet physical properties of MIL-D-3134F.
- C. Polyacrylate Terrazzo:

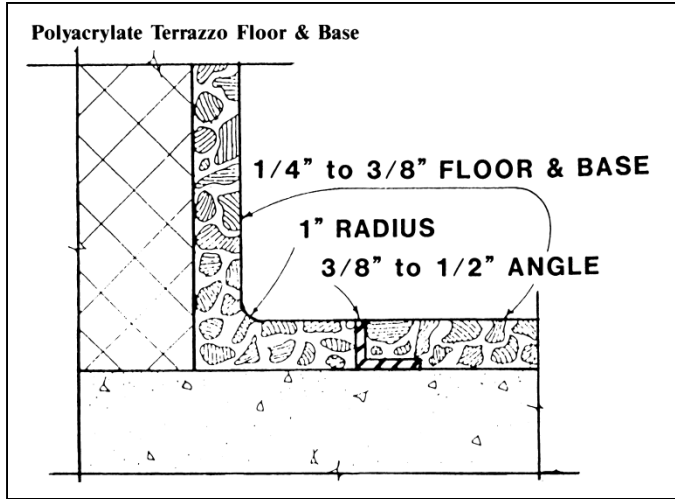

1. Odor, Fire and Toxicity Hazards: The Polyacrylic terrazzo, both before and after setting, shall not constitute an undue fire hazard, nor shall fumes from volatile substances contained in the material be more toxic than those resulting from the use of ordinary latex paint and free from objectionable odors under ordinary service conditions.
 2. Weight: Polyacrylate terrazzo shall normally weigh 3.0 pounds per square foot in a thickness of 1/4 inch or 4.5 pounds for 3/8" thickness.
 3. Resistance to Impact: The Polyacrylate terrazzo shall, when bonded securely to concrete, show no visible signs of chipping, cracking, or loss of bond when tested with 16ft lbs. 16 ft. lbs is the dropping of a 2 pound steel ball from a height of eight feet.
 4. Indentation: The Polyacrylate terrazzo shall, when bonded securely to concrete, show no signs of cracking or detachment. Initial indentation of the Polyacrylate terrazzo shall be less than 7% and more than 1% when tested in accordance with MIL-D-3134F, Section 4.7.4.
 5. Resistance to Elevated Temperature: The Polyacrylate terrazzo shall, when securely bonded to concrete, not flow or slip in any part more than 1/16 inch or soften when tested in accordance with MIL-D-3134, Section 4.7.5.
 6. Moisture Absorption: The Polyacrylate terrazzo shall not absorb more than 5% moisture based on its weight at normal atmospheric conditions when tested in accordance with MIL-D-3134F, Section 4.7.8.
 7. Resistance to Wear: The Polyacrylate terrazzo shall show wear not to exceed 0.150 inch when tested in accordance with MIL-D-3134F, Section 4.7.10.
 8. Tensile Strength: Shall be at least 700 psi after aging 28 days when tested in accordance with ASTM-C-190.
 9. Bond Strength: To damp, cured concrete, after aging 28 days shall be at least 300 psi with failure in the concrete when tested in accordance with ACI Committee #403.
 10. Flexural Strength: Shall have a minimum flexural strength of 2000 psi when tested according to ASTM-C-348.
 11. Thermal Coefficient of Expansion: Matrix material shall develop a coefficient of thermal expansion not greater than 10×10^{-6} (Test Method ASTM-C-157.)
 12. Flammability: Matrix material shall not support combustion (Test Method 15 minute suspension of sample at top of flame from Fisher Burner.)
- D. Marble Chips:
1. Size to conform with NTMA gradation standards.
NOTE: SEE PRODUCT INFORMATION
 2. Abrasion and Impact resistance when testing in accordance with ASTM C 131-89 shall not exceed 40% loss.
 3. 24-Hour absorption rate not to exceed 0.75%.
 4. Chips shall contain no deleterious or foreign matter.
 5. Dust content less than 1% by weight.
- E. Strips:
1. Stop and Divider "K" or "L" strips _____ (gauge)
_____ (material)
with a depth of _____ (inches)
for a topping thickness of _____ (inches).
NOTE: (SEE DIVIDER STRIPS) SELECT GAUGE, MATERIAL, STRIP DEPTH AND TOPPING THICKNESS. GAUGE: 18, 16 OR 14 B & S GAUGE OR 1/8, 1/4, OR 3/8 INCH HEAVY TOP. MATERIAL: WHITE ALLOY OF ZINC, BRASS OR PLASTIC STRIPS.
 2. Control joints double "L" strips _____ gauge,
_____ material,
_____ inches.
NOTE: SELECT GAUGE, MATERIAL AND DEPTH OF STRIPS, POSITIONING THEM BACK TO BACK. GAUGE: 16 OR 14 B & S GAUGE.
- F. Colorants: Alkali-resistant color stable pigments.
1. Per manufacturer's recommendations.
- G. TERRAZZO CLEANER:
1. Ph factor between 7 and 10, where applicable.
 2. Biodegradable and phosphate free.
 3. Flash point: ASTM D-56, 80 degrees Fahrenheit minimum where applicable.
- H. Sealer:
1. Ph factor between 7 and 10, where applicable.
 2. Shall not discolor or amber.
 3. Penetrating type specially prepared for use on Terrazzo.
 4. Flash Point: ASTM D 56, 80 degrees Fahrenheit minimum, where applicable.
 5. U/L listed as "Slip Resistant."

2.02 MIXES

- A. Terrazzo Selection:
1. Type: _____
NOTE: SELECT COLOR AND DESIGN FROM NTMA INFORMATION GUIDE OR COLOR PLATES. ANY DEVIATION MUST BE CLEARLY STIPULATED.
- B. Proportions:
1. Polyacrylate Terrazzo Topping: In accordance with resin supplier's recommendations.
- C. Mixing:
1. Terrazzo Topping: Charge and mix marble chips, filler and polyacrylate resin in accordance with manufacturer's recommendations.

PART 3-EXECUTION

3.01 INSPECTION

- A. Examine areas to receive terrazzo for:
1. Defects in existing work that affect proper execution of terrazzo.
NOTE: CRACKS IN SUBSTRATE WILL USUALLY BE TRANSMITTED THROUGH TOPPING TO SURFACE.
 2. Deviations beyond allowable tolerance for the concrete slab work.

NOTE: SUBFLOOR NOT TO VARY MORE THAN 1/4 INCH FROM TRUE PLANE IN 10 FEET. POLYACRYLATE TERRAZZO, AS SPECIFIED, IS NOT INTENDED TO LEVEL SUBSTRATE AND WILL ONLY FOLLOW THE CONTOUR

OF THE CONCRETE SLAB. IF, FOR ANY REASON, THE SUBCONTRACTOR QUESTIONS THE SUITABILITY OF THE SUBSTRATE FOR BONDING, ANY WORK REQUIRED TO ELIMINATE NON-CONFORMITY OF SUBSURFACE SPECIFICATIONS IS THE RESPONSIBILITY OF OTHERS, ANY MATERIALS USED TO CORRECT NONCONFORMITY MUST BE COMPATIBLE WITH POLYACRYLATE SYSTEM SELECTED AND BE APPROVED BY THE TERRAZZO CONTRACTOR.

- B. Start work only when all defects have been corrected by others.

3.02 INSTALLATION

- A. Subfloor:
1. Clean and prepare concrete subfloor according to manufacturer's instructions.
 2. Install control joints back to back above control joints in subfloor.
 3. Install divider strips as shown on drawings.
 4. Dampen concrete subfloor.
- B. Placing Terrazzo:
1. Prime subfloor in accordance with manufacturer's recommendations.
 2. Place terrazzo mixture in panels formed by divider strips. Trowel mixture to top of strips,
 3. Roll surface to remove excess slurry.
 4. Trowel to uniform surface disclosing lines of divider strips.
 5. Additional marble chips may be sprinkled on surface prior to rolling at installer's option.
- C. Curing: According to manufacturer's recommendations.
- D. Finishing:
1. Rough Grinding:
 - a. Grind with 24 or finer grit stones or with comparable diamond plates.
 - b. Follow initial grind with 80 or finer grit stones.
 2. Grouting:
 - a. Cleanse terrazzo with clean water and rinse.
 - b. Remove excess rinse water and hand apply grout using identical Portland cement, color pigments as used in topping, taking care to fill voids.
 3. Cure Grout.
NOTE: GROUT MAY BE LEFT ON TERRAZZO UNTIL ALL HEAVY AND MESSY WORK IN PROJECT IS COMPLETED.
 4. Fine Grinding:
 - a. Grind with 80 or finer grit stones until all grout is removed from surface.
 - b. Upon completion, terrazzo shall show a minimum of 70% of marble chips.
- E. Cleaning and Sealing:
1. Wash all surfaces with a neutral cleaner.
 2. Rinse with clean water and allow surface to dry.
 3. Apply sealer in accordance with manufacturer's directions.
- F. Protection:
1. Upon completion, the work shall be ready for final inspection and acceptance by the owner or his agent.
 2. The General Contractor shall protect the finished work from the time that the terrazzo contractor completes the work.

GUIDE SPECIFICATION FOR EPOXY TERRAZZO

(Revised 6/94 Supersedes all previous Specifications for Epoxy Terrazzo)

SECTION 09

EPOXY TERRAZZO

1/4" OR 3/8" nominal thickness.

PART 1-GENERAL

1.01 RELATED WORK SPECIFIED IN OTHER SECTIONS

NOTE: DELETE NONAPPLICABLE ITEMS.

- A. Furnishing and/or installation of metal lath and scratch coat.
Section _____
- B. Attachment of metal stairs, any welding and mesh reinforcing.
Section _____
- C. Furnishing and setting of floor drains.
Section _____
- D. Furnishing and setting surface hardware.
Section _____
- E. Setting of metal base beads and wood ground,
Section _____

NOTE: DELETE IN CASES WHERE JURISDICTION PERMITS TERRAZZO CONTRACTOR TO INSTALL.

- F. Backing for Epoxy Terrazzo base must be cement board or exterior grade plywood, concrete block, concrete or cement plaster.
- G. Concrete subfloor,
Section _____

NOTE: CONCRETE SUBFLOOR TO BE LEVEL (MAXIMUM VARIATION NOT TO EXCEED 1/4 INCH IN 10 FEET) AND TO HAVE A STEEL TROWEL FINISHED SURFACE. NO CURING AGENTS OR OTHER ADDITIVES WHICH COULD PREVENT BONDING SHOULD BE USED. THE SLAB SHOULD HAVE AN EFFICIENT MOISTURE BARRIER UNDER THE CONCRETE SLAB WHEN PLACED DIRECTLY ON GRADE. SAW CUTTING OF CONTROL JOINTS MUST BE DONE BETWEEN 12-24 HOURS AFTER PLACEMENT OF THE STRUCTURAL CONCRETE.

- H. Broom clean area to receive terrazzo of loose chips, laitance and all foreign matter.
- I. Sufficient water, temporary heat and light, and adequate electric with suitable outlets connected and distributed for use within 100 feet of any working space.
NOTE: AMBIENT TEMPERATURE SHALL BE MAINTAINED AS PER MANUFACTURERS RECOMMENDATIONS, MINIMUM 50 DEGREES FAHRENHEIT.

1.02 QUALITY ASSURANCE

- A. Acceptable supplier:
 - 1. Materials furnished shall meet NTMA Specifications.
- B. Installer qualifications:
 - 1. Installer shall be a contractor member of NTMA and shall perform all work in accordance with NTMA standards.
 - 2. If installer is not a contractor member of NTMA, they shall submit a list of completed projects of a similar magnitude and complexity.

1.03 SUBMITTAL

- A. Samples:
 - 1. Submit a maximum of three samples, minimum 6" x 6" for each color and type of terrazzo.
 - 2. Submit two, 6" minimum lengths of each type and kind of divider strips.
- B. Maintenance Literature:
 - 1. Submit two copies of maintenance recommendations of NTMA or maintenance product members of NTMA.
- C. Certification:
 - 1. Suppliers shall furnish certification attesting that materials meet specification requirements.
 - 2. Suppliers shall furnish properly labeled material and Material Safety Data Sheets which comply to current state and federal requirements.

1.04 DELIVERY, STORAGE AND HANDLING

- A. Delivery of materials:
 - 1. Deliver materials in a manner to prevent damage to containers and/or bags.
- B. Storage of materials:
 - 1. Store materials in a clean, dry and heated (if necessary) location (50 -90 degrees Fahrenheit) furnished by others.

1.05 GUARANTEE

One year from date of substantial completion of Terrazzo installation.

PART 2-PRODUCTS

2.01 MATERIALS

- A. Primer: As recommended by Epoxy Resin Supplier.

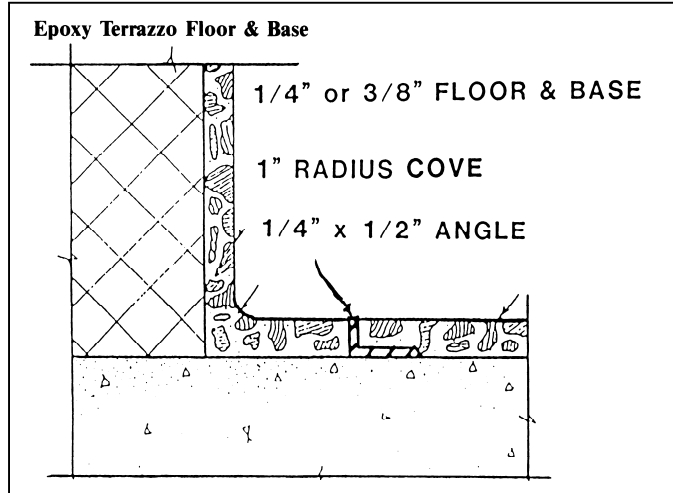

Terrazzo Specifications & Design Guide

- B. Epoxy resin mixed according to manufacturers recommendation and tested without aggregate added. All specimens cured for 7 days at 75 degrees plus or minus 2 degrees Fahrenheit and 50% plus or minus 2 R.H. The product shall meet the following requirements:

PROPERTY	TEST METHOD	REQUIREMENT
HARDNESS	ASTM D-2240 using Shore D Durometer	60 -85
TENSILE STRENGTH	ASTM D-638 run at .2" min. Specimen made using "C" die listed in ASTM D-412	3,000 psi min.
COMPRESSIVE STRENGTH	ASTM D-695, Specimen B cylinder	10,000 psi min
CHEMICAL RESISTANCE	ASTM D-1308 -7 days at room temperature by immersion method have no deleterious effects.	
	The following contaminants used:	
	Distilled Water 1% Soap Solution	
	Mineral Water 10% Sodium Hydroxide	
	Isopropanol.....10% Hydrochloric Acid	
	Ethanol30% Sulfuric Acid	
	.025 Detergent Solution5% Acetic Acid	

- C. Epoxy Resin mixed according to manufacturers recommendations and blended with 3 volumes of Georgia White marble blended 60% #1 chip and 40% #0 chip, ground and grouted with epoxy resin according to 3.02 C-2-Finishing to a nominal 1/4" thickness. All specimens cured 7 days at 75 degrees plus or minus 2 degrees Fahrenheit and 50% plus or minus 2% R.H. The finished epoxy terrazzo shall meet the following requirements:

1. Flammability: When tested in accordance with ASTM-D-635, the Epoxy terrazzo shall comply with the following value: Self-extinguishing, extent of burning 0.25 inches maximum.
2. Thermal Coefficient of Linear Expansion: when tested in accordance with ASTM-D-696, the Epoxy terrazzo will comply with the following value: 25 x 10⁻⁶ inches per inch per degrees to 140 degrees Fahrenheit maximum. Temperature range -12 degrees to 140 degrees Fahrenheit.
3. Bond Strength: When tested in accordance with Field Test Method for surface soundness and adhesion as described in ACI Committee No. 403 Bulletin Title No. 59-43 (Pages 1139-1141) the Epoxy terrazzo shall comply with the following value: 100% concrete failure minimum, with 300 PSI minimum tensile strength.
NOTE: THIS TEST IS INTENDED TO EVALUATE THE BOND TO THE CONCRETE SUBFLOOR. A 100% CONCRETE FAILURE INDICATES A GOOD BOND.

- D. Marble Chips:

1. Size: To conform with NTMA gradation standards.
NOTE: SEE PRODUCT INFORMATION.
2. Abrasion and Impact resistance when testing in accordance with ASTM C 131-89 shall not exceed 40% loss.
3. 24 Hour absorption rate not to exceed 0.75 percent.
4. Chips shall contain no deleterious or foreign matter.
5. Dust content less than 1% by weight.

- E. Strips:

1. Stop and divider "L" strips _____ gauge.
(Select gauge white alloy of zinc or plastic. Consult with manufacturer of epoxy resin if brass strips are desired.)
NOTE: SELECT GAUGE FROM FOLLOWING GAUGE 18, 16, OR 14 B & S GAUGE OR 1/8, 1/4 OR 3/8 INCH HEAVY TOP "L" OR "K" TYPE. 2. CONSTRUCTION JOINT DOUBLE "L" STRIPS, BACK TO BACK...16 GAUGE WHITE ALLOY OF ZINC MATERIAL.

- F. Terrazzo Cleaner:

1. Ph factor between 7 and 10, where applicable.
2. Biodegradable and phosphate free.

- G. Sealer:

1. Ph factor between 7 and 10, where applicable.
2. Shall not discolor or amber
3. Flash point: ASTM D-56, 80 degrees Fahrenheit minimum, where applicable.
4. U/L listed as "Slip Resistant."

2.02 MIXES

- A. Terrazzo Selection:

1. Type: _____
NOTE: SELECT COLOR AND DESIGN FROM NTMA INFORMATION GUIDE OR COLOR PLATES. ANY DEVIATION MUST BE CLEARLY STIPULATED.

- B. Proportions:

1. Epoxy Terrazzo Topping: In accordance with resin supplier's recommendations.

- C. Mixing:

1. Terrazzo Topping: Charge and mix marble chips, filler and epoxy resin in accordance with manufacturer's recommendations.

PART 3-EXECUTION

3.01 INSPECTION

- A. Examine areas to receive terrazzo for defects in existing work that affect proper execution of Epoxy Terrazzo.

1. Defects in existing work that affect proper execution of terrazzo.
NOTE: CRACKS IN SUBSTRATE WILL USUALLY BE TRANSMITTED THROUGH TOPPING TO SURFACE.
2. Deviations beyond allowable tolerance for the concrete slab work.

NOTE: SUBFLOOR NOT TO VARY MORE THAN 1/4 INCH FROM TRUE PLANE IN 10 FEET. EPOXY TERRAZZO, AS SPECIFIED, IS NOT INTENDED TO LEVEL SUBSTRATE AND WILL ONLY FOLLOW THE CONTOUR OF THE CONCRETE SLAB. IF, FOR ANY REASON, THE SUBCONTRACTOR QUESTIONS THE SUITABILITY OF THE SUBSTRATE FOR BONDING, ANY WORK REQUIRED TO ELIMINATE NON-CONFORMITY OF SUBSURFACE SPECIFICATIONS IS THE RESPONSIBILITY OF OTHERS, ANY MATERIALS USED TO CORRECT NONCONFORMITY MUST BE COMPATIBLE WITH EPOXY SYSTEM SELECTED AND BE APPROVED BY THE TERRAZZO CONTRACTOR.

- B. Start work only when all defects have been corrected by others.

3.02 INSTALLATION

- A. Subfloor:
1. Prepare substrate to receive epoxy terrazzo in accordance with manufacturer's recommendations.
 2. Install control joints directly above control joints in subfloor.
 3. Install divider strips as shown on drawings.
- B. Placing Terrazzo:
1. Prime subfloor in accordance with manufacturer's recommendations.
 2. Place terrazzo mixture in panels formed by divider strips. Trowel mixture to top of strips.
- C. Finishing:
1. Rough Grinding:
 - a. Grind with 24 or finer grit stones or with comparable diamond plates.
 - b. Follow initial grind with 80 or finer grit stones.
 2. Grouting:
 - a. Cleanse terrazzo with clean water and rinse.
 - b. Remove excess rinse water and hand apply grout using identical color as used in topping, taking care to fill voids.
 3. Cure Grout.
NOTE: GROUT MAY BE LEFT ON TERRAZZO UNTIL ALL HEAVY AND MESSY WORK IN PROJECT IS COMPLETED.
 4. Fine Grinding:
 - a. Grind with 80 or finer grit stones until all grout is removed from surface.
 - b. Upon completion, terrazzo shall show a minimum of 70% of marble chips.
- D. Cleaning and Sealing:
1. Wash all surfaces with a neutral cleaner.
 2. Rinse with clean water and allow surface to dry.
 3. Apply sealer in accordance with manufacturer's directions.
- E. Protection:
1. Upon completion, the work shall be ready for final inspection and acceptance by the owner or his agent.
 2. The General Contractor shall protect the finished work from the time that the terrazzo contractor completes the work.

GUIDE SPECIFICATION FOR CONDUCTIVE EPOXY TERRAZZO

SECTION 09 CONDUCTIVE EPOXY TERRAZZO

The following should be added to the Epoxy Resin Terrazzo Specification.

2.01 MATERIALS

- H. Resin Epoxy Terrazzo:
7. Conductivity: Meet or exceed all the requirements of Bulletin 56A of the National Fire Prevention Association for Conductive Floors.
NOTE: 1.01.H.7 THIS REQUIREMENT CALLS FOR CONDUCTIVE FLOORS TO HAVE AN ELECTRICAL RESISTANCE OF LESS THAN 1,000,000 OHMS AND MORE THAN 25,000 OHMS

GUIDE SPECIFICATIONS FOR CONDUCTIVE POLYESTER TERRAZZO

SECTION 09 CONDUCTIVE POLYESTER TERRAZZO

The following should be added to the Polyester Resin Terrazzo Specification.

2.01 MATERIALS

- J. Polyester Terrazzo:
15. Conductivity: Meet or exceed all the requirements of Bulletin 56A of the National Fire Prevention Association for conductive floors.
NOTE: 2.01.J/15 THIS REQUIREMENT CALLS FOR CONDUCTIVE FLOORS TO HAVE AN ELECTRICAL RESISTANCE OF LESS THAN 1,000,000 OHMS AND MORE THAN 25,000 OHMS.

GUIDE SPECIFICATION FOR POLYESTER TERRAZZO

(Revised 6/94 Supersedes all previous Specifications for Polyester Terrazzo)

SECTION 09 POLYESTER TERRAZZO 1/4 Inch Nominal Thickness.

PART 1-GENERAL

1.01 RELATED WORK SPECIFIED IN OTHER SECTIONS

NOTE: DELETE NONAPPLICABLE ITEMS.

- A. Furnishing and/or installation of metal lath and scratch coat.
Section _____
- B. Attachment of metal stairs, any welding and mesh reinforcing.
Section _____
- C. Furnishing and setting of floor drains.
Section _____
- D. Furnishing and setting surface hardware.
Section _____
- E. Setting of metal base beads and wood ground,
Section _____

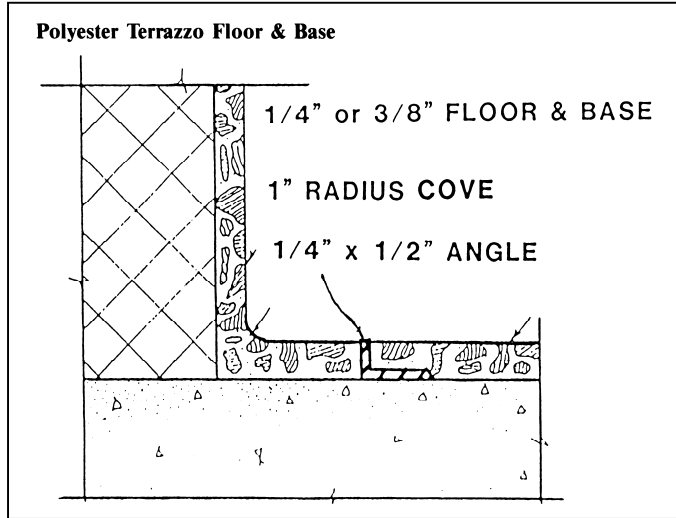

NOTE: DELETE IN CASES WHERE JURISDICTION PERMITS TERRAZZO CONTRACTOR TO INSTALL.

- F. Backing for Polyester Terrazzo base must be cement board or exterior grade plywood, concrete block, concrete or cement plaster.
Section _____
- G. Concrete subfloor,
Section _____

NOTE: SUBFLOOR TO BE LEVEL (SHOULD NOT VARY MORE THAN 1/4" FROM A TRUE PLANE IN 10 FEET) AND HAVE A STEEL TROWEL FINISHED SURFACE. NO CURING AGENTS OR OTHER ADDITIVES WHICH COULD PREVENT BONDING SHOULD BE USED. THE SLAB SHOULD HAVE AN EFFICIENT MOISTURE BARRIER UNDER THE CONCRETE SLAB WHEN PLACED DIRECTLY ON GRADE. SAW CUTTING OF CONTROL JOINTS MUST BE DONE BETWEEN 12-24 HOURS AFTER PLACEMENT OF STRUCTURAL CONCRETE.

- H. Broom clean area to receive terrazzo of loose chips, laitance and all foreign matter.
- I. Sufficient water, temporary heat and light, and adequate electric with suitable outlets connected and distributed for use within 100 feet of any working space.

NOTE: AMBIENT FLOOR TEMPERATURE SHALL BE MAINTAINED AS PER MANUFACTURER RECOMMENDATIONS, MINIMUM 50 DEGREES FAHRENHEIT.

1.02 QUALITY ASSURANCE

- A. Acceptable supplier:
 - 1. Materials furnished shall meet NTMA Specifications.
- B. Installer qualifications:
 - 1. Installer shall be a contractor member of NTMA and shall perform all work in accordance with NTMA standards.
 - 2. If installer is not a contractor member of NTMA, they shall submit a list of completed projects of a similar magnitude and complexity.

1.03 SUBMITTAL

- A. Samples:
 - 1. Submit a maximum of three samples, minimum 6" x 6" for each color and type of terrazzo.
 - 2. Submit two, 6" minimum lengths of each type and kind of divider strips.
- B. Maintenance Literature:
 - 1. Submit two copies of maintenance recommendations of NTMA or maintenance product members of NTMA.
- C. Certification:
 - 1. Suppliers shall furnish certification attesting that materials meet specification requirements.
 - 2. Suppliers shall furnish properly labeled material and Material Safety Data Sheets which comply to current state and federal requirements.

1.04 DELIVERY, STORAGE AND HANDLING

- A. Delivery of materials:
 - 1. Deliver materials in a manner to prevent damage to containers and/or bags.
- B. Storage of materials:
 - 1. Store materials in a clean, dry and heated (if necessary) location (50 -90 degrees Fahrenheit) furnished by others.

1.05 GUARANTEE

One year from date of substantial completion of Terrazzo installation.

PART 2-PRODUCTS

2.01 MANUFACTURER MATERIALS TEST

- A. Primer: As recommended by polyester resin supplier.
- B. Polyester Resin: Resin shall perform in accordance with the following requirements:

Compressive Strength, psi	12,000.....	ASTM-D-695-61 T
Flexural Strength, psi	7,000.....	ASTM-D-790-61
Flexural Modulus, psi	500,00-700,00	
Tensile Strength, psi.....	5,000 min.....	ASTM-D-412
% Elongation	2.0-4.0.....	ASTM-D-412
Hardness, Shore D.....	60-85.....	ASTM-D-2240
Specific Gravity	2.3-2.4.....	ASTM-D-792
Water Absorption, % max.....	0-0.15.....	ASTM-D-570
Abrasion Resistance, loss in Inches.....	0-.0001.....	Tabor Fed. Test
% Wt. Loss03.....	Method Std. #141
		Method 6192-for
		1000 cycles, using
		CS-17 wheels &
		1000 gm load.

- C. Polyester Terrazzo Mix
 1. Curing Time: The Polyester Terrazzo shall cure within 18 hours in an atmosphere of 73 degrees Fahrenheit plus or minus 5 degrees and a relative humidity of 50 plus or minus 10 percent: in accordance with ASTM-C-308-77.
 2. Shrinkage Resistance: The Polyester Terrazzo shall shrink not more than 1/32 inch in 12 inches and shall show no evidence of cracking, spalling or ridging.
 3. Chemical Resistance: The Polyester terrazzo shall exhibit no evidence of change in color, blistering, cracking, peeling or loss of adhesion after 48 hours when tested in accordance with ASTM-C-267-77.
 4. Fumigant Resistance: The Polyester terrazzo shall show no evidence of deterioration such as blistering, cracking, peeling or loss of adhesion upon cyclic exposure to formaldehyde, or beta prepicolactone in accordance with ASTM-C- 267-77.
 5. Abrasion Resistance: The Polyester terrazzo shall lose not more than 1 mil thickness after 1,000 cycles of a Taber abraser when tested in accordance with Federal Test Method-6192.
 6. Hardness: The Polyester terrazzo shall have a hardness of not less than 80 when tested in accordance with ASTM D- 2240-75.
 7. Porosity: The Polyester Terrazzo shall gain not more than 8 percent in weight and shall exhibit no evidence of cracking, peeling, blistering or loss of adhesion after submersion in distilled water for 24 hours when tested in accordance with ASTM-D-570-77.
 8. Water Absorption: ASTM-D-570, 24 hours, 0.10 max.
 9. Impact Resistance: The Polyester terrazzo shall show no evidence of cracking, spalling, or loss of adhesion after exposure to a minimum of 144 inch pounds of force in a Gardner impact test.
 10. Thermal Shock Resistance: The Polyester Terrazzo shall not crack, peel, blister, spall or lose adhesion after 50 cycles of immersion in chilled and boiling water at 2-minute intervals.
 11. Stain Resistance: The Polyester terrazzo shall not retain a permanent stain when exposed for 24 hours to staining agent when tested in accordance with ASTM-D-1308-57.
 12. Flammability: The Polyester terrazzo shall obtain a rating of "self extinguishing" when tested in accordance with ASTM-D-635-63.
 13. Compressive Strength: ASTM-C-579 - 8,000 psi min.
 14. Bond Strength: ACI Committee #403 - 100% concrete failure, and 200 psi minimum tensile strength.
- D. Marble Chips:
 1. Size: To conform with NTMA gradation standards.
NOTE: SEE PRODUCT INFORMATION.
 2. Abrasion and Impact resistance when testing in accordance with ASTM C 131-89 shall not exceed 40% loss.
 3. 24 Hour absorption rate not to exceed 0.75 percent.
 4. Chips shall contain no deleterious or foreign matter.
 5. Dust content less than 1% by weight.
- E. Strips:
 1. Stop and divider "L" strips _____ gauge.
(Select gauge white alloy of zinc or plastic. Consult with manufacturer of epoxy resin if brass strips are desired)
NOTE: SELECT GAUGE FROM FOLLOWING GAUGE 18, 16, OR 14 B & S GAUGE OR 1/8, 1/4 OR 3/8 INCH HEAVY TOP "L" OR "K" TYPE.
 2. Construction joint double "L" strips, back to back...16 gauge white alloy zinc or brass material.
- F. Terrazzo Cleaner:
 1. Ph factor between 7 and 10, where applicable.
 2. Free from crystallizing salts or water soluble alkaline salts.
 3. Biodegradable and phosphate free.
- G. Sealer:
 1. Ph factor between 7 and 10, where applicable.
 2. Shall not discolor or amber.
 3. Flash point: ASTM D-56, 80 degrees Fahrenheit minimum, where applicable.
 4. U/L listed as "Slip Resistant."

2.02 MIXES

- A. Terrazzo Selection:
 1. Type: _____
NOTE: SELECT COLOR AND DESIGN FROM NTMA INFORMATION GUIDE OR COLOR PLATES. ANY DEVIATION MUST BE CLEARLY STIPULATED.
- B. Proportions:
 1. Polyester Terrazzo Topping: In accordance with resin supplier's recommendations.
- C. Mixing:
 1. Terrazzo Topping: Charge and mix marble chips, filler and polyester resin in accordance with manufacturer's recommendations.

PART 3-EXECUTION

3.01 INSPECTION

- A. Examine areas to receive terrazzo for defects in existing work that work that affect proper execution of terrazzo.
 - 1. Defects in existing work that affect proper execution of terrazzo.
NOTE: CRACKS IN SUBSTRATE WILL USUALLY BE TRANSMITTED THROUGH TOPPING TO SURFACE.
 - 2. Deviations beyond allowable tolerance for the concrete slab work.
NOTE: SUBFLOOR NOT TO VARY MORE THAN 1/4 INCH FROM A TRUE PLANE IN 10 FEET. POLYESTER TERRAZZO, AS SPECIFIED, IS NOT INTENDED TO LEVEL SUBSTRATE AND WILL ONLY FOLLOW THE CONTOUR OF THE CONCRETE SLAB. IF, FOR ANY REASON, THE SUBCONTRACTOR QUESTIONS THE SUITABILITY OF THE SUBSTRATE FOR BONDING, ANY WORK REQUIRED TO ELIMINATE NON-CONFORMITY OF SUBSURFACE SPECIFICATIONS IS THE RESPONSIBILITY OF OTHERS, ANY MATERIALS USED TO CORRECT NONCONFORMITY MUST BE COMPATIBLE WITH POLYESTER SYSTEM SELECTED AND BE APPROVED BY THE TERRAZZO CONTRACTOR.
- B. Start work only when all defects have been corrected by others.

3.02 INSTALLATION

- A. Subfloor:
 - 1. Prepare substrate to receive polyester terrazzo.
 - 2. Install control joints directly above control joints in subfloor.
 - 3. Install divider strips as shown on drawings.
- B. Placing Terrazzo:
 - 1. Prime subfloor in accordance with resin supplier's recommendations.
 - 2. Place terrazzo mixture and trowel to a dense flat surface to top of divider strip.
- C. Finishing:
 - 1. Rough Grinding:
 - a. Grind with 24 or finer grit stones or with comparable diamond plates.
 - b. Follow initial grind with 80 or finer grit stones.
 - 2. Grouting:
 - a. Cleanse terrazzo with clean water and rinse.
 - b. Remove excess rinse water and hand apply grout using identical color as used in topping, taking care to fill voids.
 - 3. Cure Grout.
NOTE: GROUT MAY BE LEFT ON TERRAZZO UNTIL ALL HEAVY AND MESSY WORK IN PROJECT IS COMPLETED.
 - 4. Fine Grinding:
 - a. Grind with 80 or finer grit stones until all grout is removed from surface.
 - b. Upon completion, terrazzo shall show a minimum of 70% of marble chips.
- D. Cleaning and Sealing:
 - 1. Wash all surfaces with a neutral cleaner after fine grinding.
 - 2. Rinse with clean water and allow surface to dry.
 - 3. Apply sealer in accordance with manufacturer's directions.
- E. Protection:
 - 1. Upon completion, the work shall be ready for final inspection and acceptance by the owner or his agent.
 - 2. The General Contractor shall protect the finished work from the time that the flooring contractor completes the work.

GUIDE SPECIFICATION FOR USE OF EPOXY TERRAZZO ACCENT FEATURES IN SAND CUSHION TERRAZZO

(Revised 6/97 Supersedes all previous specifications for Epoxy Sand Cushion Terrazzo)

NOTE: THIS SPECIFICATION ENABLES DESIGNERS TO INTRODUCE ACCENT FEATURES IN A CEMENTITIOUS SAND CUSHION FLOOR THAT ARE ONLY POSSIBLE WITH EPOXY TERRAZZO (I.E. BRIGHT COLORS OR SYNTHETIC CHIPS.)

SECTION 09

EPOXY SAND CUSHION TERRAZZO

Minimum of 2-1/2 inches thick (3/8 inch minimum Epoxy terrazzo topping, 2-1/8 inch nominal underbed includes sand dusting on concrete substrate.) See Architectural Details.

PART 1 - GENERAL

1.01 RELATED WORK SPECIFIED IN OTHER SECTIONS

NOTE: DELETE NON-APPLICABLE ITEMS.

A. Furnishing and installation of metal lathe and scratch coat,
Section _____

B. Attachment of metal stairs, any welding and/or reinforcing,
Section _____

C. Furnishing and setting floor drains,
Section _____

D. Furnishing and setting surface hardware,
Section _____

E. Setting of metal base beads and wood grounds,
Section _____

NOTE: DELETE WHERE JURISDICTION PERMITS TERRAZZO CONTRACTOR TO INSTALL.

F. Concrete subfloor,
Section _____

NOTE: SUBFLOOR SHALL NOT VARY MORE THAN 1/4 INCH FROM TRUE PLANE IN 10 FOOT SPAN WITH FLOAT FINISH.

G. Broom clean area to receive terrazzo of loose chips and all foreign matter.

H. Sufficient water, temporary heat and light, and adequate electric power with suitable outlets connected and distributed for use within 100 feet of any work space.

NOTE: AMBIENT TEMPERATURES SHALL BE MAINTAINED AT A MINIMUM OF 50 DEGREES FAHRENHEIT.

1.02 QUALITY ASSURANCE

A. Acceptable Suppliers:

1. Suppliers shall provide materials in accordance with the NTMA standards.

B. Acceptable Installer:

1. Installer shall be a contractor member of NTMA.

2. If installer is not a contractor member of NTMA, installer shall submit a list of completed projects of similar magnitude and complexity.

3. All work is to be installed in accordance with NTMA standards.

1.03 SUBMITTAL

A. Samples:

1. Submit a maximum of three samples, sizes 6 inches x 6 inches for each color and type of terrazzo specified.

2. Submit two, 6-inch lengths of each type and kind of divider strip as specified.

B. Maintenance Literature:

1. Submit two copies of NTMA maintenance recommendations.

C. Certification:

1. Suppliers shall furnish certification attesting that materials meet specification requirements.

2. Suppliers shall furnish properly labeled material and Material Safety Data Sheets which comply with current state and federal requirements.

1.04 DELIVERY, STORAGE, AND HANDLING

A. Delivery of Materials:

1. Deliver materials in a manner to prevent damage to containers and/or bags.

B. Storage of Epoxy Materials:

1. Store materials in a clean, dry, heated location (50-80 degrees F) furnished by others.

1.05 GUARANTEE

One year from date of completion of terrazzo installation.

PART 2 - PRODUCTS

2.01 MATERIALS

A. Primer: 100% Solids as recommended by Epoxy Resin Supplier.

B. Epoxy resin mixed according to manufacturers recommendation and tested without aggregate added. All specimens cured for 7 days at 75 degrees plus or minus 2 degrees Fahrenheit and 50% plus or minus 2 R.H. The product shall meet the following requirements:

1. Underbed: One part Portland cement to Three parts sand and sufficient water to provide workability at as low a slump as possible.
2. Epoxy Terrazzo Topping: In accordance with resin supplier's recommendations.

PART 3 - EXECUTION

3.01 INSPECTION

- A. Examine areas to receive terrazzo for:
 1. Defects in existing work that affect proper execution of terrazzo work.
 2. Deviations beyond allowable tolerances for the concrete slab work.
- B. Start work only when all defects have been corrected by others.

3.02 INSTALLATION

- A. Underbed:
 1. Cover entire surface to receive terrazzo with dusting of sand.
 2. Install isolation membrane overlapping ends and edges a minimum of 3 inches.
 3. Install welded wire reinforcement:
 - a. Overlap wire at edges and ends at least 2 squares.
 4. Place underbed mix.
 5. Screed underbed to elevation _____ inch below finished floor elevation or slope. (3/8 depending on terrazzo topping.)
 6. Install divider strips as shown on drawings in semi-plastic underbed and trowel firmly along edges.
 7. Cure underbed. Test for sufficient cure prior to placing terrazzo. (Mat test or similar.)
- B. Placing Terrazzo:
 1. Prime subfloor in accordance with manufacturer's recommendations.
 2. Place terrazzo mixture in panels formed by divider strips. Trowel mixture to top of strips.
- C. Finishing:
 1. Rough Grinding:
 - a. Grind with 24 or finer grit stones or with comparable diamond plates.
 - b. Follow initial grind with 80 or finer grit stones.
 2. Grouting:
 - a. Cleanse terrazzo with clean water, rinse, and allow to dry.
 - b. Apply manufacturer's Epoxy grout.
 3. Cure Grout.

NOTE: GROUT MAY BE LEFT ON TERRAZZO UNTIL ALL HEAVY AND MESSY WORK IN PROJECT IS COMPLETED.

 4. Fine Grinding:
 - a. Grind with 80 or finer grit stones until all grout is removed from surface.
 - b. Upon completion, terrazzo shall show a minimum of 70% of marble chips.
- D. Cleaning and Sealing:
 1. Wash all surfaces with a neutral cleaner.
 2. Rinse with clean water and allow surface to dry.
 3. Apply sealer in accordance with manufacturer's directions.
- E. Protection:
 1. Upon completion, the work shall be ready for final inspection and acceptance by the owner or his agent.
 2. The General Contractor shall protect the finished from the time that the terrazzo contractor completes the work.

**GUIDE SPECIFICATIONS FOR TROWEL FINISH EPOXY FLOORS
INTERIOR USE ONLY**

(Revised 6/94 Supersedes all previous Specifications for Trowel Finish Epoxy Floors)

**SECTION 09
TROWEL FINISH EPOXY FLOORS**

1/4 inch nominal thickness-decorative or industrial-troweled epoxy flooring.

NOTE: MINOR TROWELING IRREGULARITIES MAY BE REFLECTED IN FINAL FLOOR FINISH. FLOOR SURFACING SHALL BE ONE OF THE FOLLOWING (SELECT TYPE DESIRED):

TYPE 1: FLOOR SURFACING CONSISTING OF EPOXY MATRIX MATERIAL AND GRADED CERAMIC OR OTHERWISE COATED AGGREGATE. GROUTED AND SEALED WITH A CLEAR BINDER TO ACHIEVE A NONPOROUS SURFACE.

TYPE 2: FLOOR SURFACING CONSISTING OF EPOXY MATRIX AND GRADED MARBLE OR GRANITE AGGREGATE. GROUTED AND SEALED WITH A CLEAR BINDER TO ACHIEVE A NONPOROUS SURFACE.

TYPE 3: FLOOR SURFACING CONSISTING OF COLORED EPOXY MATRIX MATERIAL AND GRADED SILICA, QUARTZ, OR OTHER HARD AGGREGATE. GROUTED AND SEALED WITH THE SAME COLOR BINDER TO ACHIEVE A NONPOROUS SURFACE.

PART 1-GENERAL

1.01 RELATED WORK SPECIFIED IN OTHER SECTIONS

NOTE: DELETE NONAPPLICABLE ITEMS.

- A. Furnishing and/or installation of metal lath and scratch coat.
Section _____
- B. Attachment of metal stairs, any welding and mesh reinforcing.
Section _____
- C. Furnishing and setting of floor drains.
Section _____
- D. Furnishing and setting surface hardware.
Section _____
- E. Setting of metal base beads and wood ground,
Section _____
NOTE: DELETE IN CASES WHERE JURISDICTION PERMITS TERRAZZO CONTRACTOR TO INSTALL.
- F. Backing for Troweled Epoxy Terrazzo base must be cement board or exterior grade plywood, concrete block, concrete or Cement plaster.
- G. Concrete subfloor,
Section _____
NOTE: SUBFLOOR SHOULD NOT VARY MORE THAN 1/4" FROM A TRUE PLANE IN 10 FEET AND HAVE A STEEL TROWEL FINISHED SURFACE. NO CURING AGENTS OR OTHER ADDITIVES WHICH COULD PREVENT BONDING SHOULD BE USED. THE SLAB SHOULD HAVE AN EFFICIENT MOISTURE BARRIER UNDER THE CONCRETE SLAB WHEN PLACED DIRECTLY ON GRADE. SAW CUTTING OF CONTROL JOINTS MUST BE DONE BETWEEN 12-24 HOURS AFTER PLACEMENT OF STRUCTURAL CONCRETE.
- H. Broom clean area to receive epoxy flooring of loose chips, laitance and all foreign matter.
- I. Sufficient water, temporary heat and light, and adequate electric with suitable outlets connected and distributed for use within 100 feet of any working space.
NOTE: AMBIENT FLOOR TEMPERATURE SHALL BE MAINTAINED AS PER MANUFACTURER RECOMMENDATIONS, MINIMUM 50 DEGREES FAHRENHEIT.

1.02 QUALITY ASSURANCE

- A. Acceptable supplier:
 - 1. Materials furnished shall meet NTMA Specifications.
- B. Installer qualifications:
 - 1. Installer shall be a contractor member of NTMA and shall perform all work in accordance with NTMA standards.
 - 2. If installer is not a contractor member of NTMA, they shall submit a list of completed projects of a similar magnitude and complexity.

1.03 SUBMITTAL

- A. Samples:
 - 1. Submit a maximum of three samples, minimum 6" x 6" for each color and type of epoxy flooring.
 - 2. Submit two, 6" minimum lengths of each type and kind of divider strips.
- B. Maintenance Literature:
 - 1. Submit two copies of maintenance recommendations of NTMA or maintenance product members of NTMA.
- C. Certification:
 - 1. Suppliers shall furnish certification attesting that materials meet specification requirements.
 - 2. Suppliers shall furnish properly labeled material and Material Safety Data Sheets which comply to current state and federal requirements.

3. Suppliers shall furnish complete instructions for any cautions or special handling of materials in order to comply with the Occupational Safety and Health Act.
4. Submit two copies of NTMA maintenance recommendations.

1.04 DELIVERY, STORAGE AND HANDLING

- A. Delivery of materials:
 1. Deliver materials in a manner to prevent damage to containers and/or bags.
- B. Storage of materials:
 1. Store materials in a clean, dry and heated (if necessary) location (50 -90 degrees Fahrenheit) furnished by others.

1.05 GUARANTEE

One year from date of substantial completion of epoxy flooring installation.

PART 2-PRODUCTS

2.01 MATERIALS

- A. Primer: As recommended by Epoxy resin supplier.
- B. Epoxy resin: Shall be suitable for application by trowel to a finished thickness of 1/4" nominal thickness in a system approach. Material shall be pitched to a drain and form a vertical cove base where specified. Epoxy resin mixed according to manufacturer recommendations and tested without aggregate added. All specimens cured for 7 days at 75 degrees plus or minus 2 degrees Fahrenheit and 50% plus or minus 2% R.H. The product shall meet the following requirements.

PROPERTY	TEST METHOD	REQUIREMENT
HARDNESS	ASTM D-2240 using Shore D Durometer	70 min
TENSILE STRENGTH	ASTM D-638 run at 0.2" min. Specimen made using "C" die listed in ASTM D-412	3,000 PSI min.
TENSILE ELONGATION	ASTM-D-638 run at 0.2"/min. Specimen made using "C" die listed in ASTM D-412	5.0% min.
COMPRESSIVE STRENGTH	ASTM D-695, Specimen B Cylinder	12,000 psi min
CHEMICAL RESISTANCE	Federal test method standard 406 method 7011, 7-day immersion. <i>NOTE: CHEMICAL RESISTANCE LIST MAY BE MODIFIED TO CHANGE REQUIREMENTS AS SPECIFIED.</i>	
	Mineral oil - no effect ASTM No. 3 - no effect Lard - no effect Isopropanol - no effect Ethanol - no effect 10% Hydrochloric Acid - no effect 30% Sulfuric Acid - no effect 5% Acetic Acid - no effect 0.025% Detergent - no effect 1% Soap Solution - no effect 10% Sodium Hydroxide - no effect Distilled Water - no effect	
WATER ABSORPTION	ASTM-D-570, 24 Hours	0.10% max

- C. Properties of formulated, trowel-applied material:
 1. Color: Troweled epoxy surfacing shall have the aggregate color blend or solid color as specified.
 2. Resistance to impact: Epoxy surfacing, when bonded securely to the concrete substrate, shall not show visible signs of chipping, cracking or lose bond from a 2 pound steel ball dropping vertically from the height of 8 feet. (16 foot pounds.)
 3. Thermal coefficient of linear expansion: When tested in accordance with ASTM-D-696, The epoxy floor material will comply with the following value: 15 x 10⁻⁶ inches per degree Fahrenheit maximum.
 4. Bond strength: When tested in accordance with field test method for surface soundness and adhesion as described in ACI Committee No. 403 Bulletin Title No. 59-43 (pages 1139-1141) the epoxy flooring surface shall comply with the following value: 1005 concrete failure minimum with 200 PSI minimum tensile strength.
 5. Chemical Resistance: The epoxy floor system shall exhibit no evidence of change in color, blistering, cracking, peeling, or loss of adhesion after 48 hours when tested in accordance with ASTM-C-267.
 6. Abrasion resistance: The epoxy floor system shall not lose more than .030 grams per 1,000 cycles using a Taber Abraser with CS-17 wheels and a 1,000 gram load on each arm. (Federal Test Method 6192)
 7. Porosity: The epoxy floor system shall gain not more than 8 percent in weight and shall exhibit no evidence of cracking, peeling, blistering, or loss of adhesion after submersion in distilled water for 24 hours when tested in accordance with ASTM-D-570.
 8. Thermal shock resistance: The epoxy floor system shall not crack, peel, blister, spall, or lose adhesion after 5 cycles of immersion in chilled and boiling water at 24-hour intervals. (Modified ASTM-C-884)
 9. Stain Resistance: The epoxy floor system shall not leave a permanentstain when exposed for 24 hours to staining agents testing in accordance with ASTM-D-1308.

10. Compressive strength: ASTM-C-579...10,000 psi min.

- D. Aggregate 1: As specified by material supplier for each type as specified.
1. TYPE 1: Shall be a ceramic coated translucent aggregate of graded size for good troweling and blending as specified.
NOTE: TROWELED SYSTEM CANNOT BE GROUND OR SEVERELY SANDED TO ELIMINATE TROWEL IMPERFECTIONS. GRINDING WILL CHANGE THE COLOR OF THE FINISHED FLOOR.
 2. TYPE 2: Shall be graded (size #0) marble or granite chip, properly blended for correct color blend, washed and dried for minimum dust content. Common marble and granite (Not washed or dried) are not suitable.
NOTE: TROWELED SYSTEMS CAN BE GROUND TO ELIMINATE MINOR TROWEL IRREGULARITIES WITHOUT CHANGING COLOR APPEARANCE.
 3. TYPE 3: Shall be grades silica, quartz or other hard aggregate as specified. Color is not determined by color of aggregate.
- E. Grout and seal coat: To be specified by the manufacturer to provide specific wear qualities, chemical and stain resistance, as specified.
NOTE: SPECIFIC PERFORMANCE REQUIREMENTS REGARDING THE ABOVE QUALITIES MAY CHANGE DEPENDING ON REQUIREMENTS AS SPECIFIED.

2.02 MIXES

- A. Color: Color and blends as selected, provided by material supplier.
- B. Proportions: In accordance with resin supplier recommendations.
- C. Blending: Troweled epoxy material and aggregate shall be mixed in accordance with manufacturer's instructions. Grout and sealer mixed in accordance with manufacturer's instructions.

PART 3-EXECUTION

3.01 INSPECTION

- A. Examine areas to receive epoxy flooring for defects in existing work that work that affect proper execution of epoxy flooring.
 1. Defects in existing work that affect proper execution of epoxy flooring.
NOTE: CRACKS IN SUBSTRATE WILL USUALLY BE TRANSMITTED THROUGH TOPPING TO SURFACE.
 2. Deviations beyond allowable tolerance for the concrete slab work.
NOTE: SUBFLOOR NOT TO VARY MORE THAN 1/4 INCH FROM TRUE PLANE IN 10 FEET. EPOXY SYSTEM, AS SPECIFIED, IS NOT INTENDED TO LEVEL SUBSTRATE AND WILL ONLY FOLLOW THE CONTOUR OF THE CONCRETE SLAB. IF, FOR ANY REASON, THE SUBCONTRACTOR QUESTIONS THE SUITABILITY OF THE SUBSTRATE FOR BONDING, ANY WORK REQUIRED TO ELIMINATE NONCONFORMITY OF SUBSURFACE SPECIFICATIONS IS THE RESPONSIBILITY OF OTHERS, ANY MATERIALS USED TO CORRECT NON-UNIFORMITY MUST BE COMPATIBLE WITH EPOXY SYSTEM SELECTED AND BE APPROVED BY THE FLOORING CONTRACTOR.
- B. Start work only when all defects have been corrected by others.

3.02 INSTALLATION

- A. Subfloor:
 1. Prepare substrate to receive epoxy flooring in accordance with manufacturer's recommendations.
 2. Install control joints, if required, precisely above substrate joints.
 3. Install divider strips as shown on drawings.
- B. Placing Epoxy Flooring:
 1. Prime substrate as manufacturer's recommendations.
 2. Place mixture in strict accordance with manufacturer's instructions.
- C. Grout and seal coats: Apply in strict accordance with manufacturer's instructions.
- D. Protection:
 1. Upon completion, the work shall be ready for final inspection and acceptance by the owner or his agent.
 2. The General Contractor shall protect the finished work from the time that the flooring contractor completes the work.

GUIDE SPECIFICATIONS FOR FINE AGGREGATE EPOXY FLOORS INTERIOR USE ONLY

(Revised 6/94 Supersedes all previous Specifications for Aggregate Epoxy Floors)

SECTION 09

FINE AGGREGATE EPOXY FLOORS

1/8 inch nominal thickness-decorative, broadcast ceramic or otherwise coated aggregate epoxy flooring.

PART 1-GENERAL

1.01 RELATED WORK SPECIFIED IN OTHER SECTIONS

NOTE: DELETE NONAPPLICABLE ITEMS.

- A. Furnishing and/or installation of metal lath and scratch coat.
Section _____
- B. Attachment of metal stairs, any welding and mesh reinforcing.
Section _____
- C. Furnishing and setting of floor drains.
Section _____
- D. Furnishing and setting surface hardware.
Section _____
- E. Setting of metal base beads and wood ground,
Section _____

NOTE: DELETE IN CASES WHERE JURISDICTION PERMITS TERRAZZO CONTRACTOR TO INSTALL.

- F. Backing for Fine aggregate epoxy base must be cement board or exterior grade plywood, concrete block, concrete or Cement plaster.
- G. Concrete subfloor,
Section _____
NOTE: CONCRETE SUBFLOOR TO BE LEVEL (MAXIMUM VARIATION NOT TO EXCEED 1/4 INCH IN 10 FEET) AND HAVE A STEEL TROWEL FINISHED SURFACE. NO CURING AGENTS OR OTHER ADDITIVES WHICH COULD PREVENT BONDING SHOULD BE USED. THE SLAB SHOULD HAVE AN EFFICIENT MOISTURE BARRIER UNDER THE CONCRETE SLAB WHEN PLACED DIRECTLY ON GRADE. SAW CUTTING OF CONTROL JOINTS MUST BE DONE BETWEEN 12-24 HOURS AFTER PLACEMENT OF STRUCTURAL CONCRETE.
- H. Broom clean area to receive epoxy of loose chips, laitance and all foreign matter.
- I. Sufficient water, temporary heat and light, and adequate electric with suitable outlets connected and distributed for use within 100 feet of any working space.
NOTE: AMBIENT FLOOR TEMPERATURE SHALL BEE MAINTAINED AS PER MANUFACTURER RECOMMENDATIONS, MINIMUM 50 DEGREES FAHRENHEIT.

1.02 QUALITY ASSURANCE

- A. Acceptable supplier:
 - 1. Materials furnished shall meet NTMA Specifications.
- B. Installer qualifications:
 - 1. Installer shall be a contractor member of NTMA and shall perform all work in accordance with NTMA standards.
 - 2. If installer is not a contractor member of NTMA, they shall submit a list of completed projects of a similar magnitude and complexity.

1.03 SUBMITTAL

- A. Samples:
 - 1. Submit a maximum of three samples, minimum 6" x 6" for each color and type of epoxy flooring.
 - 2. Submit two, 6" minimum lengths of each type and kind of divider strips.
- B. Maintenance Literature:
 - 1. Submit two copies of maintenance recommendations of NTMA or maintenance product members of NTMA.
- C. Certification:
 - 1. Suppliers shall furnish certification attesting that materials meet specification requirements.
 - 2. Suppliers shall furnish properly labeled material and Material Safety Data Sheets which comply to current state and federal requirements.
 - 3. Submit two copies of manufacturers maintenance recommendations.

1.04 DELIVERY, STORAGE AND HANDLING

- A. Delivery of materials:
 - 1. Deliver materials in a manner to prevent damage to containers and/or bags.
- B. Storage of materials:
 - 1. Store materials in a clean, dry and heated (if necessary) location (50-90 degrees Fahrenheit) furnished by others.

1.05 GUARANTEE

One year from date of substantial completion of epoxy flooring installation.

PART 2-PRODUCTS

2.01 MATERIALS

- A. Primer: As recommended by Epoxy resin supplier.

- B. Epoxy resin mixed according to manufacturer’s recommendations and tested without aggregate added. All specimens cured for 7 days at 75 degrees plus or minus 2 degrees Fahrenheit and 50% plus or minus 2% R.H. The product shall meet the following requirements.

PROPERTY	TEST METHOD	REQUIREMENT
HARDNESS	ASTM D-2240 using Shore D Durometer	60–85
TENSILE STRENGTH	ASTM D-638 run at 0.2" min. Specimen made using “C” die listed in ASTM D-412	3,000 PSI min.
TENSILE ELONGATION	ASTM-D-638 run at 0.2"/min. Specimen made using “C” die listed in ASTM D-412	5.0% min.
COMPRESSIVE STRENGTH	ASTM D-695, Specimen B Cylinder	10,000 psi min
FLEXURAL STRENGTH	ASTM-D-790	6,000 psi min
FLEXURAL MODULUS OF ELASTICITY	ASTM-D-790	1 x 104 PSI min
LINEAR SHRINKAGE	ERF-64	0.001inches/one inch max.
ABRASIVE RESISTANCE		ASTM-C-501 72 Mg.
CHEMICAL RESISTANCE:	Federal test method standard 406 method 7011, 7-day immersion. Mineral oil - no effect ASTM No. 3 oil - no effect Lard - no effect Isopropanol - no effect Ethanol - no effect 10% Hydrochloric Acid - no effect 30% Sulfuric Acid - no effect 5% Acetic Acid - no effect 0.025% Detergent - no effect 1% Soap Solution - no effect 10% Sodium Hydroxide - no effect Distilled Water - no effect	

- C. Bond Strength:
When tested in accordance with Field Test Method for surface soundness and adhesion as described in ACI Committee No. 403 Bulletin Title 59-43 (Pages 1139-1141), the Epoxy resin shall comply with the following value 100% concrete failure minimum with 300 psi minimum tensile strength.
- D. Fine Aggregate:
1. Ceramic coated translucent quartz.
NOTE: CERAMIC COATED TRAP ROCK OR OTHER DARK FINE AGGREGATE SHOWS DISCOLORATION WITH WEAR.
- E. Grout coat: As recommended by epoxy resin supplier.
- F. Seal coat: As recommended by epoxy resin supplier.

2.02 MIXES

- A. Color: Select from color blends provided by supplier.
- B. Proportions: In accordance with resin supplier recommendations.

PART 3-EXECUTION

3.01 INSPECTION

- A. Examine areas to receive fine aggregate epoxy flooring for:
1. Defects in existing work that affect proper execution of epoxy flooring.
NOTE: CRACKS IN SUBSTRATE WILL USUALLY BE TRANSMITTED THROUGH TOPPING TO SURFACE.
2. Deviations beyond allowable tolerance for the concrete slab work.
NOTE: SUBFLOOR NOT TO VARY MORE THAN 1/4 INCH FROM TRUE PLANE IN 10 FEET. EPOXY TERRAZZO, AS SPECIFIED, IS NOT INTENDED TO LEVEL SUBSTRATE AND WILL ONLY FOLLOW THE CONTOUR OF THE CONCRETE SLAB. IF, FOR ANY REASON, THE SUBCONTRACTOR QUESTIONS THE SUITABILITY OF THE SUBSTRATE FOR BONDING, ANY WORK REQUIRED TO ELIMINATE NONCONFORMITY OF SUBSURFACE SPECIFICATIONS IS THE RESPONSIBILITY OF OTHERS, ANY MATERIALS USED TO CORRECT NONCONFORMITY MUST BE COMPATIBLE WITH EPOXY SYSTEM SELECTED AND BE APPROVED BY THE TERRAZZO CONTRACTOR.
- B. Start work only when all defects have been corrected by others.

3.02 INSTALLATION

- A. Subfloor:
 - 1. Prepare substrate to fine aggregate flooring in accordance with manufacturer's recommendations.
 - 2. Install control joints, if required, precisely above substrate joints.
 - 3. Install divider strips, if required.
- B. Placing epoxy flooring:
 - 1. Install floor system in strict accordance with manufacturer's instructions.
NOTE: SPECIFIED SYSTEM IS INTENDED TO BE A DECORATIVE "BROADCAST" SYSTEM. IF TROWELED PROCESS IS USED, SURFACE WILL SHOW TROWEL IRREGULARITIES WHICH CANNOT BE SANDED BY GRINDING.
- C. Grout coat: Install in strict accordance with epoxy resin suppliers instructions.
- D. Seal coat: Apply in strict accordance with epoxy resin suppliers instructions.
- E. Protection:
 - 1. Upon completion, the work shall be ready for final inspection and acceptance by the owner or his agent.
 - 2. The General Contractor shall protect the finished work from the time that the flooring contractor completes the work.

GUIDELINE SUGGESTIONS FOR SPECIFICATION OF CONCRETE SLAB-ON-GRADE SUBSTRATES TO RECEIVE EPOXY TERRAZZO

PART 1 - SCOPE

1.01 WORK INCLUDED:

1.1.1 This guide covers the work necessary to furnish and install, complete, cast in place concrete for floor slabs on grade, and all necessary items in accordance with these specifications and drawings. This specification is intended to provide concrete of sufficient quality to allow for the successful installation of very low permeability floor finishes and reduce the incidence of floor finishes failures due to common moisture-related problems in slabs on grade. This specification will help to minimize shrinkage cracks.

1.1.2 See CONDITIONS OF CONTRACT, and Division 1, GENERAL REQUIREMENTS, which contain information and requirements that apply to the work specified herein.

1.2 SUBMITTALS:

1.2.1 Drawings showing location of construction joints

1.2.2 Provide technical data sheets, application instructions and a 12" x 12" sample of vapor barrier

1.2.3 Concrete mix design and trial mix laboratory reports to include:

- a. Water-Cement Ratio
- b. Slump
- c. Air Content per ASTM C 231 or ASTM C 173
- d. Aggregate gradation
- e. Rapid Permeability test results per AASHTO T 277
- f. Compressive Strength per ASTM C 39
- g. Mix Proportions of all ingredients

1.2.4 Independent laboratory certification that aggregates to be used are non-reactive.

1.2.5 Schedule of placement sequence

1.2.6 Proposed curing schedule to include method and duration

1.2.7 Provide certification from the admixture manufacturer that the admixtures provided contain no chlorides.

1.2.8 Provide certification that the concrete batch plant has been tested and that all equipment is within the tolerances as set forth in the National Bureau of Standards Handbook No. 44.

1.3 QUALITY ASSURANCE:

1.3.1 Materials and work shall conform to the requirements of the latest version of the following codes, specifications, and standards. Should conflicts arise between these codes, specifications and standards, the more stringent shall apply.

ACI 301 Specifications for Structural Concrete for Buildings

ACI 302.1 Guide for Concrete Floor and Slab Construction

ACI 318 Building code requirements for Reinforced Concrete

AASHTO T 277 Standard Method of Test for Rapid Determination of the Chloride Permeability of Concrete

ASTM C 33 Standard Specification for Concrete

ASTM C 94 Standard Specification for Ready-Mixed Concrete

ASTM C 150 Standard Specification for Portland Cement

ASTM C 260 Standard Specification for Air-Entraining Admixtures for Concrete

ASTM C 494 Standard Specification for Chemical Admixtures for Concrete

ASTM C 171 Standard Specification for Sheet Materials for Curing Concrete

ASTM C 138 Standard Test Method for Unit Weights, Yield, and Air Content (Gravimetric) of Concrete

1.3.2 Engage a testing laboratory acceptable to the architect to perform material evaluation tests and to design concrete mixes.

1.3.3 Materials and installed work may require testing and retesting at any time during the progress of work. Tests, including retesting or rejected materials for installed work, shall be done at the Contractor's expense.

1.4 RELATED WORK SPECIFIED IN OTHER SECTIONS:

Section No.	Item
03210	Reinforcing Steel
03251	Expansion and Construction joints
05500	Fabricated Metalwork and Castings (Embedded Items)
07194	Under slab Vapor Retarder
07900	Joint Sealant
09400	Terrazzo
09500	Wood Flooring
09650	Resilient Flooring
09800	Special Coatings
	Other

PART 2 - CONCRETE MATERIALS

2.1 GENERAL:

Final concrete mix proportion requirements shall be determined from the trial mix laboratory results. The following requirements shall be met:

Cementitious Content (minimum)	517 lbs / yd ³
Water-Cement Ratio40 – .45
Maximum size Coarse Aggregate	1-1/2"
Air Content	4–6%
Slump (without high-range water reducers)	£ 3 inches
Slump (with high-range water reducers)	6–9 inches
Compressive Strength (28 day)	4,500 psi
Permeability	LOW
Density	140 lbs. / ft ³

2.2 CEMENT:

Portland Cement Type II or at Contractor’s option, the combination of Type I with fly ash or Type II with Silica fume mineral admixture. Cement shall meet the requirements of ASTM C 150.

2.3 WATER:

Water shall be potable, clean and free from oil, acid, alkali, organic or other deleterious substances and shall conform for ASTM C 94.

2.4 CONCRETE AGGREGATES:

Natural aggregates conforming to ASTM C 33. Aggregates shall not be potentially reactive as defined in Appendix XI of ASTM C 33. The contractor shall be responsible for meeting these specifications and shall import non-reactive aggregates if local aggregates are reactive. Aggregate shall be thoroughly and uniformly washed before use.

2.5 AIR ENTRAINING ADMIXTURE:

Admixture shall conform for ASTM C 260 and shall contain no chlorides.

2.6 WATER REDUCING ADMIXTURES:

Admixtures shall conform to ASTM C 94, Type A or Type D and shall contain no chlorides.

2.7 HIGH RANGE WATER REDUCING ADMIXTURES:

Admixture shall conform to ASTM C 494, Type F or Type G and contain no chlorides.

2.8 POZZOLAN ADMIXTURES:

The pozzolan to be used in combination with cement as previously specified shall conform to ASTM C 618, Class C or Class F.

2.9 MINERAL ADMIXTURE:

If submitted by the contractor and approved by the engineer, the silica fume material admixture used in combination with cement as previously specified shall be the dry compacted form. The contractors shall provide certification from the silica fume manufacturer that the silica fume meets the following quality criteria:

SiO ₂	85% minimum
Chlorides	0.5% maximum
L.O.I.	4% maximum
Moisture	3% maximum
Specific Surface	20 m ² / gram minimum
Bulk Density	30 lbs. / ft ³ minimum

PART 3 - RELATED MATERIALS

3.1 SUB-GRADE AND GRANULAR BASE:

Contractor shall require and receive certification that sub-grade is level and compacted, that there is a minimum of 4 inches of coarse aggregate or crushed rock, covered with a minimum of 2 inches of coarse sand.

3.2 VAPOR BARRIER:

After slab areas have been dried in and protected from the elements, provide vapor barrier cover over granular base where indicated below slabs on grade. Use only materials which are resistant to decay, are efficient water barriers and are in accordance with ASTM E 154-88/93. The minimum Perm rating must be <.090, as represented by 10 mil Polyethylene.

3.3 FORM MATERIAL:

Plywood, lumber, metal, or other acceptable material. Provide lumber dressed on at least two edges and on side, for tight fit. Do not use form materials that are designed to be left in place.

PART 4 - EXECUTION:

Coordinate the placement of vapor barriers, forms, reinforcing steel, and joint materials.

4.1 VAPOR BARRIER:

Install vapor barrier over compacted granular base to a water tight condition in accordance with the manufacturers' application instructions. The vapor barrier shall be continuous under the entire slab and all concrete below grade in compliance with ACI 504.

4.2 JOINTS:

Coordinate all joints with the structural engineer. Consult the drawings for detail conditions at joints.

4.3.1 CONSTRUCTION JOINTS:

Locate and install construction joints as indicated. If not indicated, contractor will provide shop drawings as per Section 1.2 of these specifications.

4.3.2 ISOLATION JOINTS:

Construct isolation joints at points of contact between slab and on grade and vertical surfaces and elsewhere as indicated.

4.3.3 CONTRACTION (CONTROL) JOINTS:

Construct saw cut contraction joints in accordance with ACI 302.1. Contractor shall insure that the contraction joints are saw cut to one-fourth the slab thickness as soon as possible without dislodging the coarse aggregate or ravelling the concrete surface. Contraction joints shall be constructed in a pattern such that spacing between joints of any type will not exceed thirty-six times the slab thickness.

4.4 PRE-PLACEMENT INSPECTION:

The contractor shall inspect and complete all formwork, reinforcing steel, and items to be embedded or cast in place.

4.5 PLACING CONCRETE FLOOR SLABS:

Comply with ACI 304 "Guide for Measuring, Mixing, Transporting and Placing Concrete" and ACI 302.1 "Guide to Concrete Floor and Slab Construction."

4.6 CONSOLIDATING:

Consolidate concrete by mechanical vibrating equipment supplemented by hand-spading, rodding or tamping. Do not use vibrators to move concrete horizontally. Insert and withdraw vibrators vertically only.

4.7 LEVELING:

Bring slab surfaces to correct level with straightedge and strike off. Use bull floats or darbies to smooth surface, free of humps or hollows. Do not disturb slab surfaces prior to beginning finishing operations.

4.8 FINISHING:

Apply light steel trowel finish to slab surfaces. After leveling, begin first trowel finish operation using a power-driven trowel. Begin final troweling when surface produces a ringing sound as trowel is moved over surface. Finished surface is to be free of trowel marks, uniform in texture and appearance and with surface leveled to tolerances of FF30 / FL20 with no measurement < FF15 / FL10 . Do not burnish trowel the surface.

4.9 CONCRETE CURING AND PROTECTION:

4.9. GENERAL:

Protect freshly placed concrete from premature drying and excessive cold or hot temperatures. Begin initial curing as soon as free water has disappeared from concrete surface after placing and finishing, and the surface will not be marred. Keep continuously moist for not less than 7 days by the following methods:

4.9.2 MOISTURE CURING:

Keep concrete continuously wet by covering with water, continuous fog spray, or covering the surface with burlap absorptive cover, thoroughly saturating cover with water and keeping continuously wet.

4.9.3 MOISTURE RETAINING COVER:

Protect the concrete from damage and wear during other phases of the construction using temporary coverings as necessary. Remove temporary coverings prior to final inspection.

RECOMMENDATIONS FOR MONOLITHIC TERRAZZO

A REMINDER ABOUT CONCRETE:

The strength of concrete is largely determined by the amount of water mixed in it before pouring. If too much water is present, that is, if the concrete is too "sloppy," it will be porous and weakened. In addition, some of the water rises to the surface bringing with it laitance or scum (the impurities in the cement and aggregates) and this must be removed or broomed off the surface before the surface has set-up.

On the other hand, concrete that is too stiff is not readily placed due to the lack of plasticity. It doesn't flow properly together unless vibrated or tamped. Also, concrete that is too stiff does not flow under reinforcing steel, and does not adhere to it readily. Still another problem encountered is "honeycomb", especially where steel mesh or reinforcing bars are pulled up after the concrete is placed over them. The pulling-up of the reinforcing in too-stiff concrete will leave voids or air pockets in concrete, weakening the slab and creating a condition that can cause trouble when the terrazzo is poured.

Slabs that have been made weak and porous by the excess use of water in the concrete or honeycombed by the use of too-stiff concrete present a possible danger to the terrazzo system.

Any concrete slab to which monolithic terrazzo is to be applied should be thoroughly saturated with water several hours prior to the pouring of the terrazzo. If when flooded, bubbles arise, this indicates that water is going down and air is coming up. If the terrazzo is poured at this time it would be possible for large areas of the terrazzo to be separated by air (the air being forced out of the porous or honeycombed concrete by water going down as the new terrazzo floor is being rolled.)

Therefore, it is important to place concrete with the proper slump. A 5-1/3 to 6 inch slump is good, a 4 to 4-1/2 inch slump is better if the concrete is to be vibrated in place.

We suggest that all concrete be specified in strict accordance with the recommendations of the American Concrete Institute.

JOINTS FOR CONCRETE SLABS:

Why use joints.....

As indicated above, all plastic concrete contains more water than is needed for hydration of the cement. When this extra water starts to evaporate, drying-shrinkage of the slab begins creating tensile stresses in the concrete. The tensile stresses must be relieved by providing joints in the slab.

Also, slabs of different shapes expand and shrink by different amounts. The larger the slab, the greater will be the movement. At the junction of adjoining slabs, therefore, provisions must be made to provide controlled cracking of the terrazzo adjacent to the metal strips. Slabs may experience some vertical movement due to heaving or settling of the subgrade.

There are three basic types of joints that will provide the necessary control for these characteristics. The CONTROL JOINT allows differential movement only in the plane of the floor. The ISOLATION JOINT allows differential movement in all directions. Third, the CONSTRUCTION JOINT, which allows no movement in the completed floor. Since this is difficult to achieve, construction joints should be made to act as control joints. (See details.)

The sawed control joint should be made as early as possible prior to drying shrinkage and preferably during rising temperature. Sawing during a dropping temperature may result in random diagonal cracking directly ahead of the saw. Therefore, it is generally done the morning after the concrete has been placed. Provisions for isolation joints should ordinarily be made at exterior walls and at all columns. These provisions should always follow throughout the terrazzo topping.

SUMMARY: Elimination of random cracking in slabs is a matter of investigating all the possible causes of stress to the floor. Once these are known, a control or isolation joint can reduce or eliminate the effects of stress. Limits of concrete placement per day can usually be planned to coincide with control joints, thus reducing the overall number of joints and making the placement of concrete easy. Structural slabs should control the limits on the placing of concrete so that they stop and start over beams. To ensure adequate follow-through of joint position of the job, joints should be planned in advance and indicated on the drawings.

CAUTION: THE USE OF THE LIQUID CURING COMPOUNDS FOR THE CURING OF CONCRETE SHOULD NEVER BE USED ON SLABS TO RECEIVE TERRAZZO AS IT WILL ACT DETRIMENTALLY TO THE BONDING OF THE TERRAZZO.

CONCRETE SLAB SURFACE: The slab should be level and of uniform thickness; the finished surface should not vary over 1.4 inch. All laitance shall be removed from the slab and left with a roughened or broomed finish.

Much has been said about the time element for letting concrete slabs stand before the terrazzo is applied. It is required that sufficient time be allowed for the surface of the concrete to be firmly set and prepared. On slabs that are not newly poured, experience terrazzo contractors have found no difficulty in bonding to concrete slabs that are years old, provided: 1. that the slab is thoroughly cleaned, 2. that the slab has a roughened surface, and 3. that the slab is thoroughly and completely saturated with water before the terrazzo is poured. A bonding agent may be used where the slab has a smooth finish.

NOTE: CRACKS IN OLD CONCRETE SLABS WILL USUALLY SHOW UP IN THE TERRAZZO AND WHERE POSSIBLE, DIVIDERS SHOULD BE USED AND PLACED DIRECTLY OVER THEM.

MONOLITHIC TERRAZZO:

There has never been a system developed that will control concrete expansion and contraction with 100 percent effectiveness. But, as noted above, proper consideration and anticipation of structural movement should minimize any damage to the finished floor.

Since monolithic terrazzo is an economy form of terrazzo and bonded directly to the base slab, the following recommendations are extended to ensure further satisfaction: 1. The fill dirt, (for on-grade slabs) under the concrete slab, must be puddled and tamped to create a good foundation. 2. The concrete slabs should be tamped with a concrete screeder to bring the cement to the surface; thereby closing the pores. 3. It is desirous to have all plumbing and electrical conduits placed neatly and rising at right angles through the slab. 4. When the concrete slab is set enough to walk on (approximately 45 minutes) it should be broomed to roughen it to assist and ensure a good bond. 5. In large areas, the concrete should be poured in alternating slabs, extending more control over expansion and contraction.

DIVIDER STRIPS:

There are two basic types of strips available: those that are grouted into openings prepared in the base slab (standard 1-1/4" ubc strips), and those that are cemented or nailed on the surface ("k" or angle). They are available in half hard brass, white alloy zinc and plastic. In addition to these, there is available an expansion joint strip, the use of which is recommended over all such provisions in the base slab.

When installing the standard (1-1/4") type divider strips, the narrow, sawed joint as shown in figure 4 is preferable to the wood strip method. The likelihood of the crack occurring away from the strip is greatly reduced. A strip installed in a narrow, sawed joint (sawed to no less than one third the depth of the slab) will nearly always produce a controlled crack adjacent to the strip, where it is not noticeable.

"K" or "L" strips should not have a base (the horizontal flange) larger than 1/2 inch and shall have adequate holes to allow bonding on the terrazzo to the slab.

**NOTE: THE STANDARD SOLID BASE TYPE "K" OR "L" SHOULD NOT BE USED OVER A JOINT IN THE BASE OR STRUCTURAL SLAB.
(SEE DETAILS)**

It is recommended that strips generally be installed according to the following plans. Areas of a given floor should be separated into rectangles not more than 50% longer than wide; small areas ordinarily need not be cut into lesser areas. Floors can be successfully protected by dividing them into areas to a maximum of 20' x 20' 0". Dividers should be specified and placed in or over all saw cuts. When K or angles are used to form smaller panels or design (and not located over saw cuts) it should be clearly understood that these are for aesthetic reasons only and do not perform any functional purpose.

SLAB-ON-GRADE: Pipe trenches create a weak structural slab and will crack. Dividers or expansion strips should be placed directly above each side. Also, since you cannot bridge expansion provisions with terrazzo, you must follow the provisions through to the finish floor line.